

ACE

Automation Control Equipment

NEW CATALOGUE

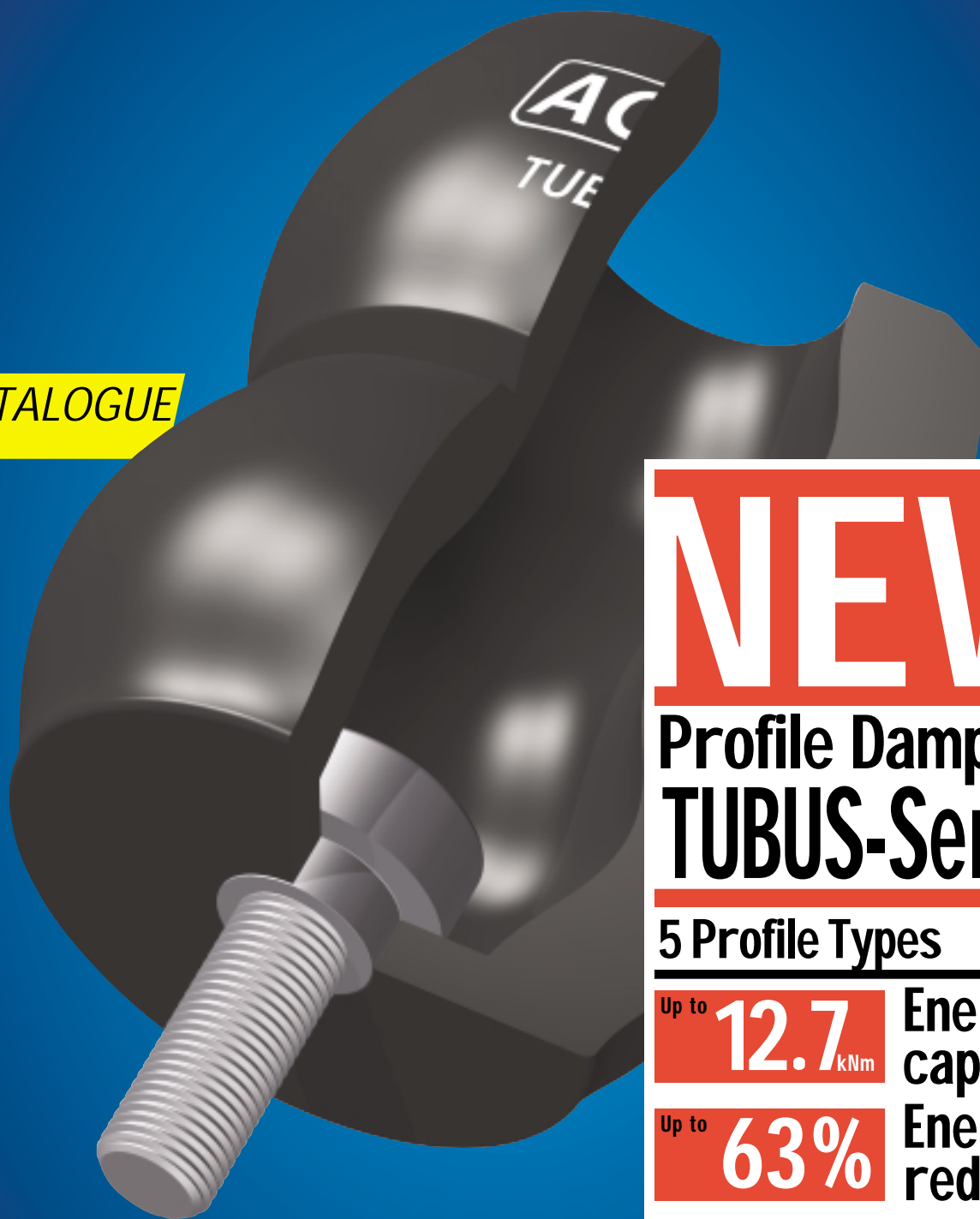

NEW

Profile Dampers TUBUS-Series

5 Profile Types

Up to	12.7 <small>kNm</small>	Energy capacity
Up to	63%	Energy reduction
Up to	150 <small>mm</small>	Stroke

For Emergency Stops

- on Machine Tools
- in Automation
- on Crane systems
- on Theme Park Rides

TUBUS - Profile Dampers from ACE are High Performance Damper elements made from a special Co-Polyester Elastomer. They have a high energy absorbing capacity compared with other materials. The TUBUS series comprises five main types with over 70 individual models. The excellent damping characteristics are achieved as a result of the special elastomer material and the worldwide patented construction design. This enables us to change the characteristic of the Elastomer material so that individual and distinct damping curves are possible.

The Profile Damper is reversible and absorbs the incoming energy with either :-

**a degressive (TA-Series),
or almost linear (TS-Series)
or progressive (TR-Series)**

Damping Characteristic.

The material does not absorb water or swell and has a high resistance to abrasion. The TUBUS Series products will work in **temperatures from -40°C up to 90°C** and are resistant against grease, oil, petroleum fluids, microbe and chemical attack and sea-water. They also have good UV and ozone resistance. The very **long Lifetime** of up to 1 Million operating cycles, the **compact size** and the **low unit weight** differentiate the **TUBUS Profile Dampers** from all other types of Elastomer Damping Elements.

If you are looking for an economic damping solution where the moving mass does not need to be decelerated to an exact datum position and where you do not need 100% absorption of the impact energy then a TUBUS Damper is a true alternative to hydraulic end position damping.

They are the preferred solution for end-stop dampers in Robotic systems, high bay warehouse systems and all similar automated machinery.

For the Crane Industry we manufacture special **High Capacity Crane Buffers** that have an ideal deceleration characteristic with high return force for this type of application. They are available with energy capacities from 450 Nm up to 12,700 Nm. This means that you can have a TUBUS Crane Buffer capable of providing up to 900 kN of braking force in a package only weighing 3 kg.

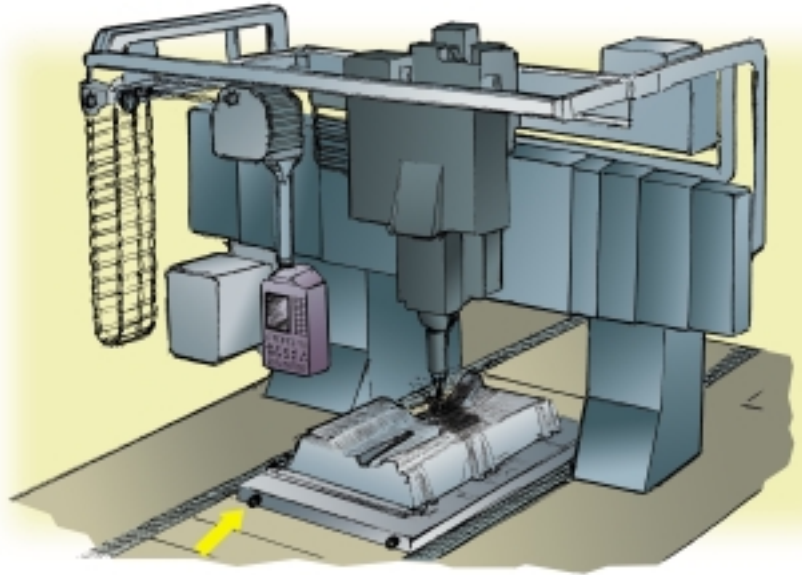

TUBUS-Profile Dampers installed in a large Machine Tool

Benefits: space saving package size, greatly reduced noise levels.

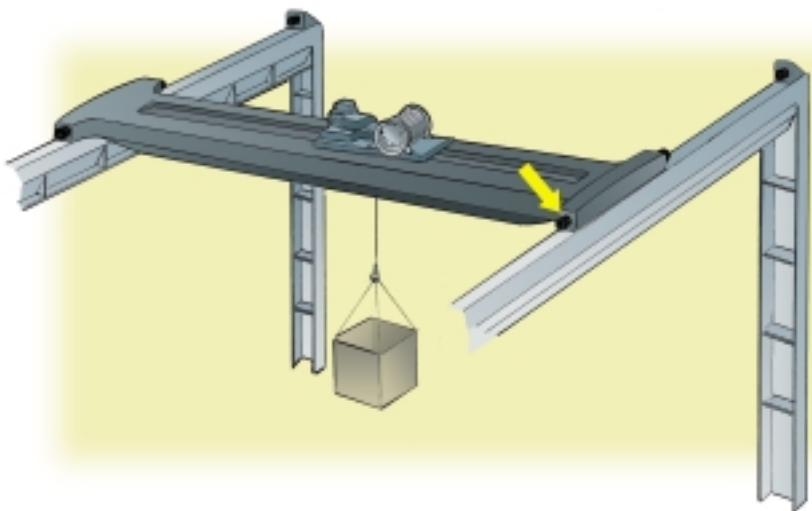

TUBUS-Profile Dampers installed in an overhead crane

Benefits: space saving construction and extremely long lifetime.

The new ACE TUBUS dampers work best in compression and withstand extreme loads. In comparison to other materials, such as rubber, urethanes and even steel springs, ACE TUBUS dampers can absorb far more energy per unit weight and volume than their closest competitor. TUBUS Profile dampers offer a considerable performance improvement. A further advantage compared to other damping elements is the operating **Life Expectancy**. This is up to **twenty times longer than with urethane dampers**, up to **ten times longer than with rubber dampers** and up to **5 times longer than with steel spring type dampers**.

Physical Properties of TUBUS Profile Dampers

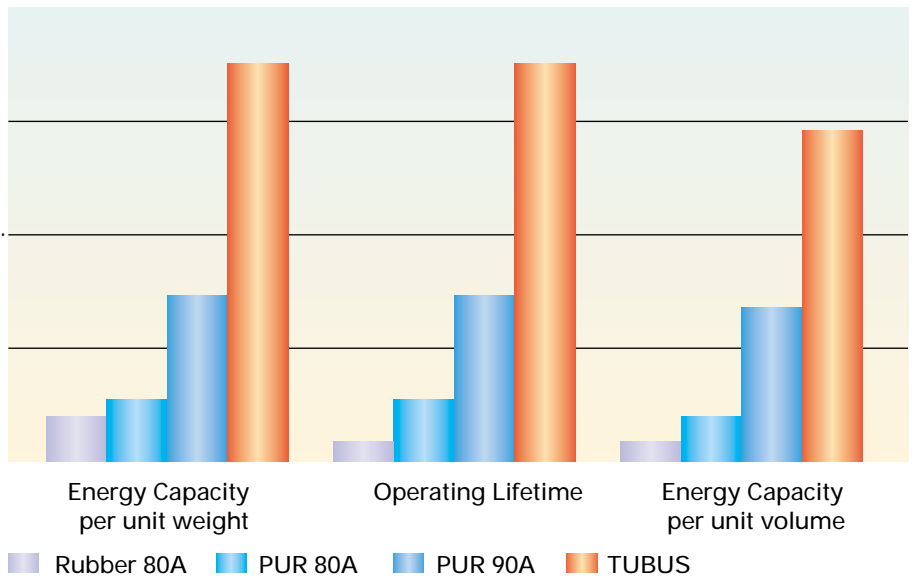

Model Type TA: Degressive Characteristic with max. Energy absorption (coloured area) with min. stroke. Energy absorption : 40 % to 66 %

Model Type TS : Almost linear Characteristic with low reaction force and short operating stroke. Energy absorption : 26 % to 56 %

Model Type TR: Progressive Characteristic with gradual reaction force increase over a long stroke length. Energy absorption : 17 % to 35 %

Comparison of Damping Characteristics

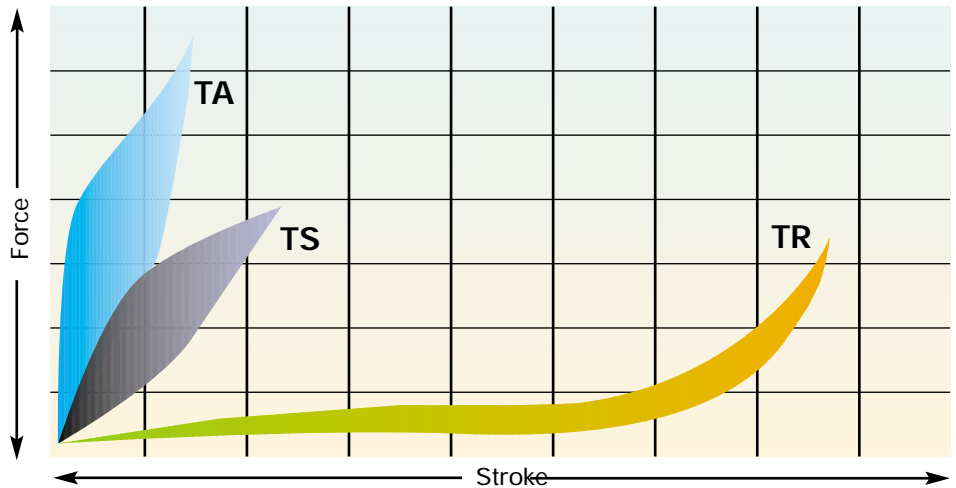

Characteristic of dynamic energy absorption for impact velocity over 1 m/s . For impact velocities under 1 m/s please request static characteristic curve.

Special Dampers

Besides the standard product range of the ACE TUBUS Series there are also a large number of special products available for customer specific applications. The universal **TubeDumper** made from the same proven Tubus material has the same profile and damping characteristics as the ACE TR series . They are available in lengths up to 1 metre long and provide essentially flat force characteristics and offer Energy capacities in the range from 100 Nm up to 9800 Nm/cycle. **On Request** we will be pleased to provide further information on successful applications on conveyor systems, pump heads , rail car draft gear and cycles and fitness equipment.



Typical special dampers

The Profile damper type TA from the innovative ACE TUBUS series is a maintenance free , self-contained Damping element made from a special Co-Polyester Elastomer. As a result of the degressive damping characteristic it provides a high energy absorption at the beginning of its stroke. The excellent temperature characteristic of the material provides consistent damping performance over a temperature range of -40°C to 90°C. The low installed weight, the economic price and the long operating life of up to 1 million cycles make this an attractive alternative to hydraulic end position damping , if the moving mass does not have to stop in an exact datum position and it is not necessary to absorb 100% of the incoming energy.

The **space-saving** package size ranges from \varnothing 22 mm up to \varnothing 115 mm and is very simply and quickly installed with the supplied specially stepped mounting screw. The TA series have been specially developed to provide **Maximum Energy Capacity** in the **Minimum Mounting Space** in the capacity range from 15 Nm up to 2000 Nm.

Life expectancy is extremely high ; **up to twenty times** longer than for urethane dampers , up to **ten times** longer than rubber bumpers and up to **five times** longer than steel springs.

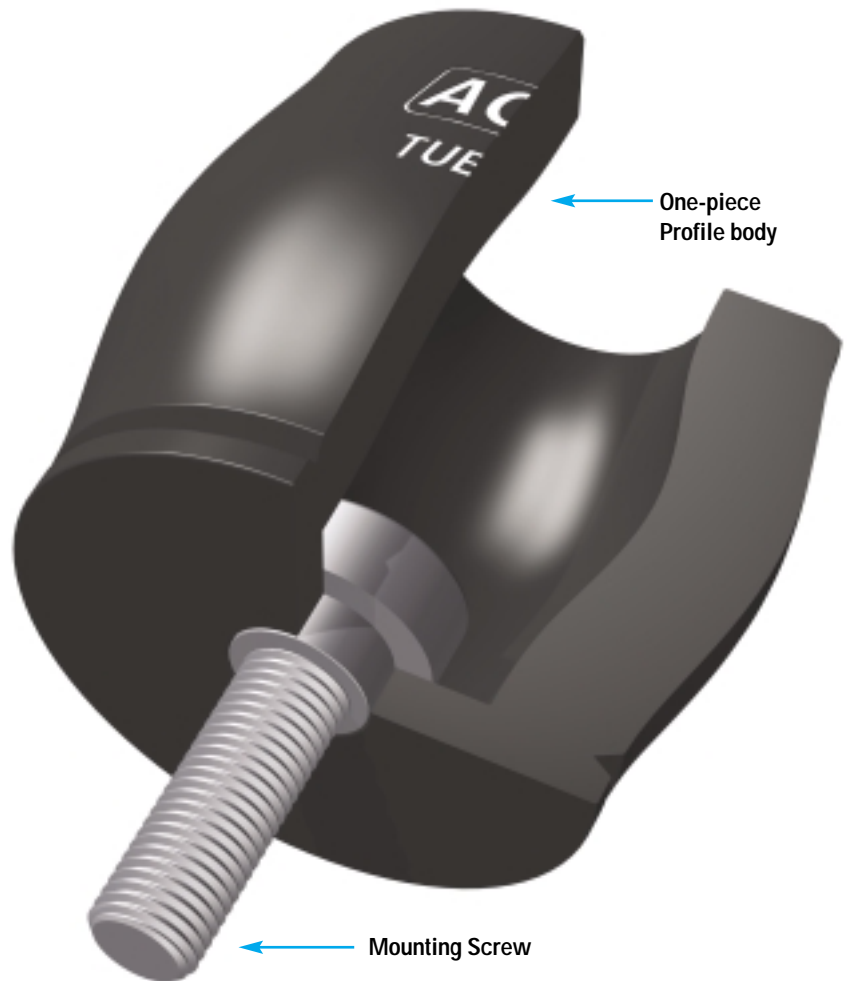

Overload Capacity : For emergency use only (1 cycle) it is possible to exceed the W3 rating by + 40%.

Environment : Resistant to oil , grease, seawater and to microbe or chemical attack. Excellent UV and ozone resistance. Material does not absorb water or swell.

Dynamic Force range : 3,100 N to 82,000 N

Temperature range : -40°C to 90°C

Energy Absorption: 40 % to 66 %

Mounting : in any position

Impact velocity range :
up to max. 5 m/s

Mounting screw torque :

M6: 10 Nm

M8: 25 Nm

M12: 85 Nm

M16: 210 Nm

On Request : Special strokes,
- characteristics, -spring rates,
- sizes and materials.

Calculation and Selection
to be approved by ACE.



Ordering Example TA 37-16

Type (Tubus axial) →
Outer -ø (37 mm) →
Stroke (16 mm) →

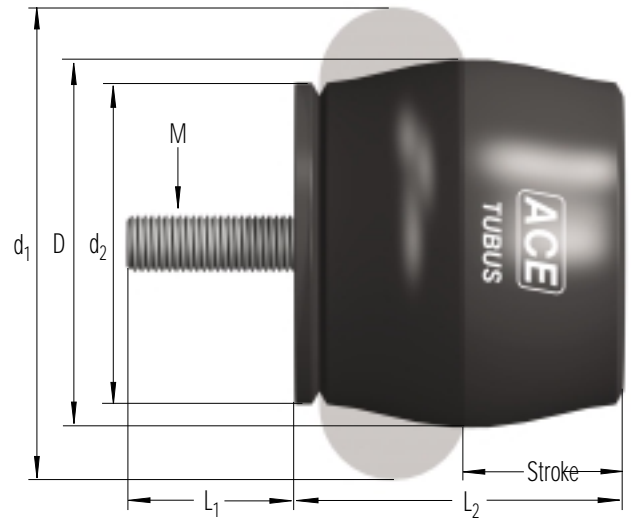

The calculation and selection of the required Profile Damper should be carried out or be approved by ACE.

Dimensions and Capacity Data

Type	*W ₃ max Nm/cycle	Stroke	D	L ₁	M	L ₂	d ₁	d ₂	Weight in gm
TA 22-10	15	10	22	6	M 6	19	27	19	5
TA 28-12	30	12	28	6	M 6	26	36	25	10
TA 34-14	50	14	34	6	M 6	30	43	30	20
TA 37-16	65	16	37	6	M 6	33	48	33	25
TA 40-16	80	16	40	8	M 8	35	50	34	30
TA 43-18	100	18	43	8	M 8	38	55	38	40
TA 47-20	130	20	47	12	M 12	41	60	41	50
TA 50-22	160	22	50	12	M 12	45	64	44	60
TA 54-22	190	22	54	12	M 12	47	68	47	65
TA 57-24	230	24	57	12	M 12	51	73	50	90
TA 62-25	280	25	62	12	M 12	54	78	53	105
TA 65-27	350	27	65	12	M 12	58	82	57	130
TA 70-29	400	29	70	12	M 12	61	86	60	145
TA 72-31	500	31	72	16	M 16	65	91	63	175
TA 80-32	600	32	80	16	M 16	69	100	69	225
TA 82-35	700	35	82	16	M 16	74	105	72	260
TA 85-36	800	36	85	16	M 16	76	110	75	300
TA 90-38	900	38	90	16	M 16	80	114	78	335
TA 98-40	1200	40	98	16	M 16	86	123	85	425
TA 116-48	2000	48	116	16	M 16	101	146	98	740

* Max Energy capacity per cycle for continuous use. For emergency use only (1 cycle) it is possible to exceed this rating by + 40 %

Characteristics

Energy - Stroke Diagram (dynamic)
(with impact velocity over 1 m/s)

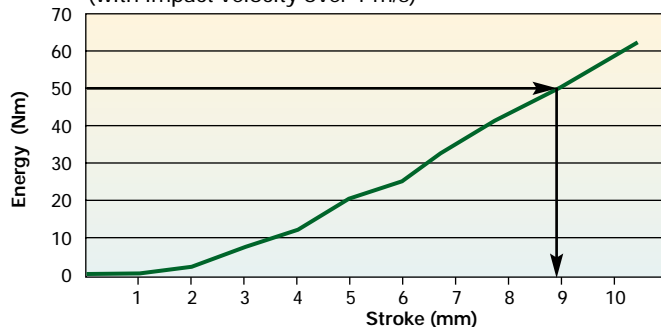

Force - Stroke Characteristic (dynamic)
(with impact velocity over 1 m/s)

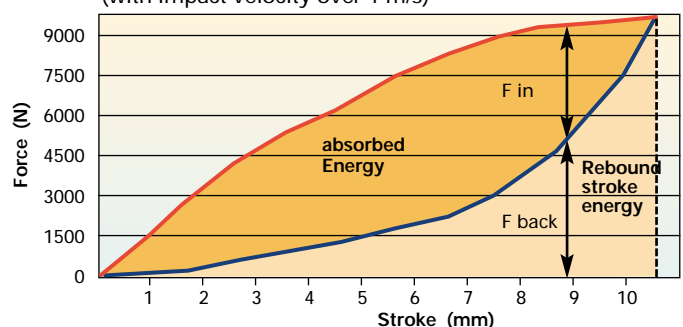

With the aid of the characteristic curves above you can estimate the proportion of the total energy that will be absorbed.
Example : With impact energy of 50 Nm the Energy-Stroke diagram shows that a stroke of about 8,8 mm is needed. On the Force-Stroke diagram you can estimate the proportion of absorbed energy to rebound energy at this stroke length.

Force characteristics are similar for all sizes. Examples above are for Model TA 37-16.
(Static characteristics for impact velocities under 0.5 m/s are available on request.)

The Profile damper Type TS from the innovative ACE TUBUS series is a maintenance free, self-contained Damping element made from a special Co-Polyester Elastomer. As a result of the almost linear damping characteristic it provides a very smooth Energy absorption with minimum reaction loads on the machine. The excellent temperature characteristic of the material provides consistent damping performance over a temperature range of - 40°C to 90°C. The low installed weight, the economic price and the long operating life of up to 1 million cycles makes this an attractive alternative to hydraulic end position damping, if the moving mass does not have to stop in an exact datum position and it is not necessary to absorb 100% of the incoming energy.

The **space-saving** package size ranges from \varnothing 20 mm up to 107 mm and is very simply and quickly installed with the supplied specially stepped mounting screw.

The TS series have been specially developed to provide **Maximum Energy Capacity** in the **Minimum Mounting Space** in the capacity range from 6 Nm up to 900 Nm.

Life expectancy is extremely high ; **up to twenty times** longer than for urethane dampers, **up to ten times** longer than rubber buffers and **up to five times** longer than steel springs.



Overload capacity : For emergency use only (1 cycle) it is possible to exceed the W3 rating by + 40%.

Environment: Resistant to oil, grease, seawater and to microbe or chemical attack. Excellent UV and ozone resistance. Material does not absorb water or swell.

Dynamic Force range : 1,300N to 24,000 N

Temperature range : -40°C to 90°C

Energy Absorption: 26% to 56%

Mounting : in any position

Impact velocity range :
up to max. 5 m/s

Mounting screw torque :

M6 : 10 Nm

M12: 85Nm

M16: 210Nm

On request : special strokes,
-characteristics, -spring rates,
- sizes and materials.

Calculation and Selection
to be approved by ACE.



Ordering Example TS 44-23

Type (Tubus axial soft) →
Outer-ø (44 mm) →
Stroke (23 mm) →

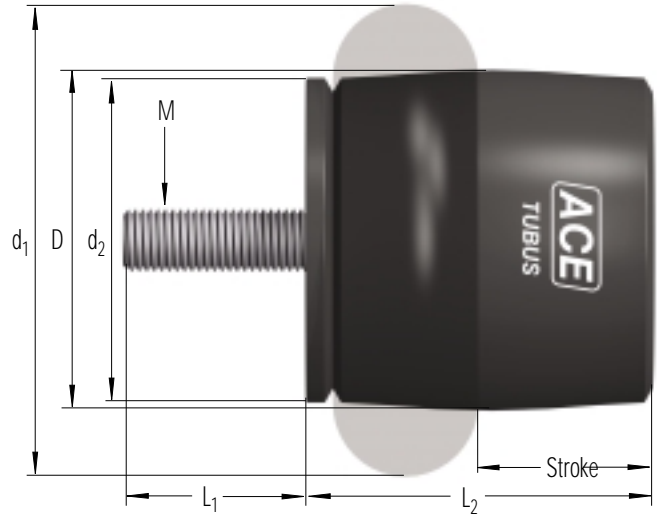

The calculation and selection of the required Profile Damper should be carried out or be approved by ACE.

Dimensions and Capacity Data

Type	*W ₃ max Nm/cycle	Stroke	D	L ₁	M	L ₂	d ₁	d ₂	Weight in gm
TS 20-10	6	10	20	6	M 6	21	27	19	5
TS 26-15	15	15	26	6	M 6	28	37	25	10
TS 32-16	25	16	32	6	M 6	32	44	30	15
TS 35-19	30	19	35	6	M 6	36	48	33	25
TS 40-19	35	19	40	6	M 6	38	51	34	30
TS 41-21	45	21	41	12	M 12	41	55	38	40
TS 44-23	65	23	44	12	M 12	45	60	40	45
TS 48-25	80	25	48	12	M 12	49	64	44	60
TS 51-27	90	27	51	12	M 12	52	69	47	70
TS 54-29	115	29	54	12	M 12	55	73	50	80
TS 58-30	135	30	58	12	M 12	59	78	53	100
TS 61-32	160	32	61	16	M 16	62	83	56	120
TS 64-34	195	34	64	16	M 16	66	87	60	145
TS 68-36	230	36	68	16	M 16	69	92	63	165
TS 75-39	285	39	75	16	M 16	75	101	69	210
TS 78-40	340	40	78	16	M 16	79	105	72	245
TS 82-44	395	44	82	16	M 16	84	110	75	275
TS 84-43	460	43	84	16	M 16	85	115	78	300
TS 90-47	565	47	90	16	M 16	92	124	84	395
TS 107-56	910	56	107	16	M 16	110	147	100	615

* Max. Energy capacity per cycle for continuous use . For emergency use only (1 cycle) it is possible to exceed this rating by + 40 %

Characteristics

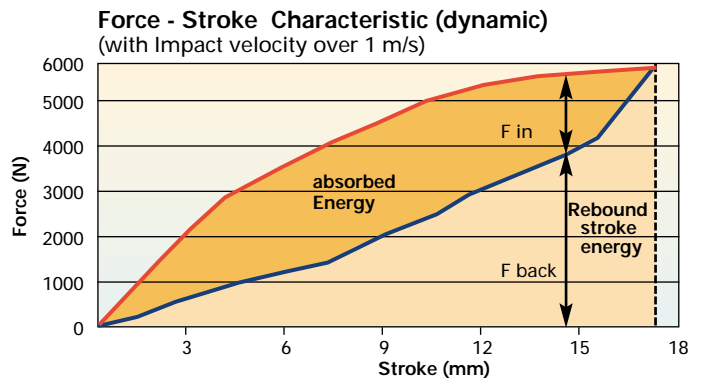
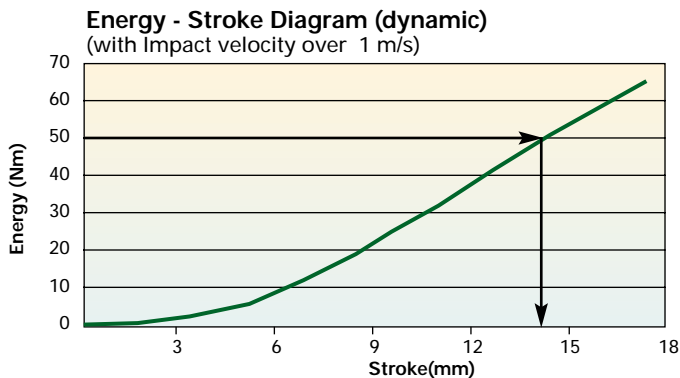

With the aid of the characteristic curves above you can estimate the proportion of the total energy that will be absorbed. Example : With impact energy of 50 Nm the Energy-Stroke diagram shows that a stroke of about 14 mm is needed. On the Force-stroke diagram you can estimate the proportion of absorbed energy to rebound energy at this stroke length.

Force characteristics are similar for all sizes. Examples above are for Model TS 44-23.
(Static characteristics for impact velocities under 0.5 m/s are available on request.)

The Profile damper Type TR from the innovative ACE TUBUS series is a maintenance free, self-contained Damping element made from a special Co-Polyester Elastomer. The radial deformation of the TR series provides a very long and soft deceleration with a progressive energy absorption towards the end of stroke. The excellent temperature characteristic of the material provides consistent damping performance over a temperature range of -40°C to 90°C. The low installed weight, the economic price and the long operating life of up to 1 million cycles makes this an attractive alternative to hydraulic end position damping, if the moving mass does not have to stop in an exact datum position and it is not necessary to absorb 100% of the incoming energy.

The **space saving** package size ranges from \varnothing 28 mm up to \varnothing 100 mm and is very simply and quickly installed with the supplied specially stepped mounting screw.

The TR Series have been specially developed to provide **Maximum Stroke** in the **Minimum Mounting Space** in the capacity range from 2Nm up to 115 Nm.

Life expectancy is extremely high; **up to twenty times** longer than for urethane dampers, **up to ten times** longer than rubber buffers and **up to five times** longer than steel springs.



Overload Capacity : For emergency use only(1 cycle) it is possible to exceed the W3 rating by + 40%.

Environment : Resistant to oil,grease,seawater and to microbe or chemical attack. Excellent UV and ozone resistance. Material does not absorb water or swell.

Dynamic Force range : 300 N to 6,200 N

Temperature range : -40°C to 90°C

Energy Absorption: 17 % to 35 %

Mounting : in any position

Impact velocity range :
up to max. 5 m/s

Mounting screw torque :

M5: 6 Nm

M6: 10 Nm

M8: 25 Nm

On request : special strokes,
-characteristics, - spring rates,
- sizes and materials.

Calculation and Selection
to be approved by ACE.



Ordering Example TR 93-57

Type (Tubus radial)
 Outer - ϕ (93 mm)
 Stroke (57 mm)

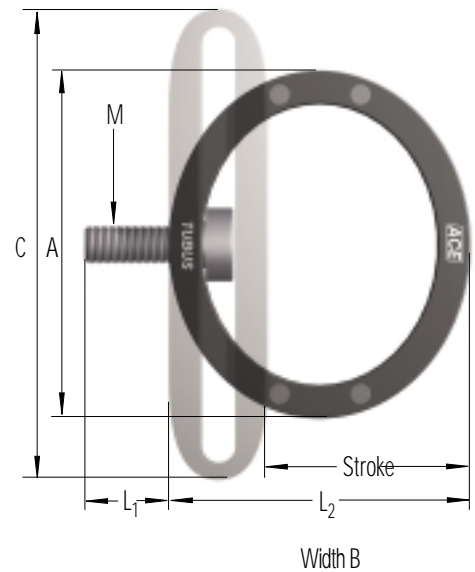

The calculation and selection of the required Profile Damper should be carried out or be approved by ACE.

Dimensions and Capacity Data

Type	*W ₃ max Nm/cycle	Stroke	A	L ₁	M	L ₂	B	C	Weight in gm
TR 29-17	2	17	29	5	M 5	25	13	38	10
TR 37-22	3	22	37	5	M 5	32	19	50	15
TR 43-25	4	25	43	5	M 5	37	20	58	20
TR 50-35	6	35	50	5	M 5	44	34	68	25
TR 63-43	15	43	63	5	M 5	55	43	87	55
TR 67-40	25	40	67	5	M 5	59	46	88	80
TR 76-46	40	46	76	6	M 6	67	46	102	105
TR 83-50	45	50	83	6	M 6	73	51	109	150
TR 85-50	70	50	85	8	M 8	73	69	111	195
TR 93-57	90	57	93	8	M 8	83	83	124	295
TR 100-60	115	60	100	8	M 8	88	82	133	335

* Max. Energy capacity per cycle for continuous use. For emergency use only (1 cycle) it is possible to exceed this rating by + 40 %

Characteristics

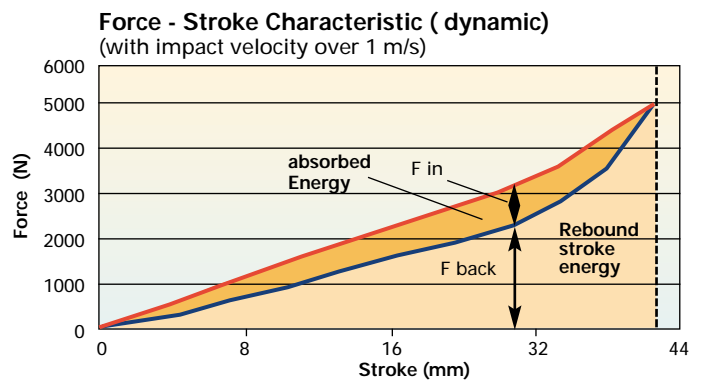
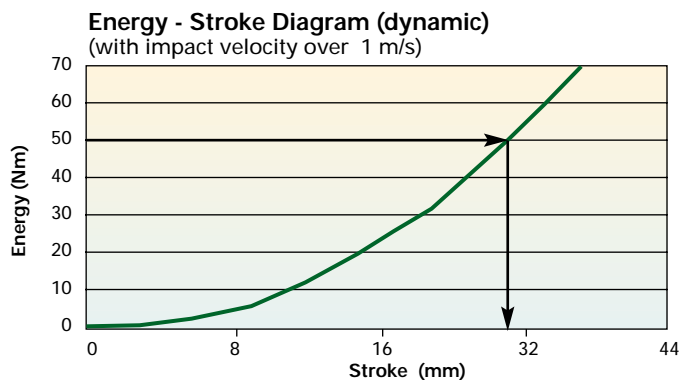

With the aid of the characteristic curves above you can estimate the proportion of the total energy that will be absorbed. Example : With impact energy of 50 Nm the Energy -Stroke diagram shows that a stroke of about 31 mm is needed. On the Force-stroke diagram you can estimate the proportion of absorbed energy to rebound energy at this stroke length.

Force characteristics are similar for all sizes. Examples above are for Model TR 93-57 .
(Static characteristics for impact velocities under 0.5 m/s are available on request.)

The radial tube Damper Type TR-L from the innovative ACE TUBUS series is a maintenance free, self-contained Damping element made from a special Co-Polyester Elastomer.

The radial deformation of the TR-L series provides a very long and soft deceleration with a progressive energy absorption towards the end of the stroke.

The excellent temperature characteristic of the material provides consistent damping performance over a temperature range of -40°C to 50°C.

The tube Damper has been specially developed for applications that require very low reaction forces. The actual force generated depends upon the length of the tube damper chosen.

The TUBUS TR-L type is suitable for a wide range of applications that require protection from shock or impact anywhere along a straight line. Typical applications include mining equipment, dockyard handling equipment and on baggage handling and conveyor systems.

The special stepped mounting screws supplied make installation very quick and simple. The TR-L Series have been developed to provide **maximum stroke** in the **minimum mounting space**.

Life expectancy is extremely high: up to **twenty times** longer than for urethane dampers, up to **ten times** longer than rubber buffers and up to **five times** longer than steel springs.



Overload Capacity : For emergency use only (1 cycle) it is possible to exceed the W3 rating by + 40% .

Environment : Resistant to oil, grease, seawater and to microbe or chemical attack. Excellent UV and ozone resistance. Material does not absorb water or swell.

Dynamic Force range : 6,800 N to 286,000 N

Temperature range :
-40°C to 50°C

Material : Shore 40D hardness.

Energy Absorption: 14% to 26%

Mounting : in any position.

Impact velocity range :
up to max. 5 m/s

Mounting screw torque :
M8: 25 Nm
M16: 210 Nm

On request : special strokes,
- colours, - sizes and materials.

Calculation and Selection
to be approved by ACE .



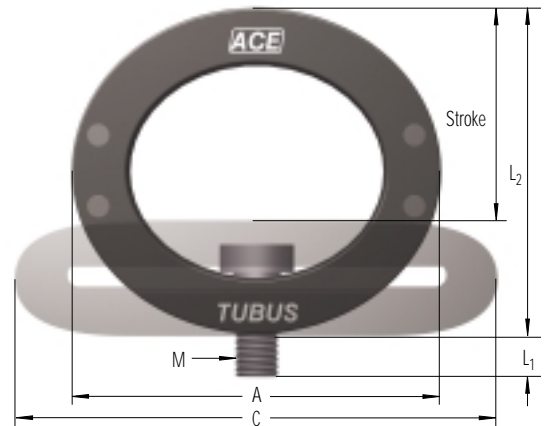
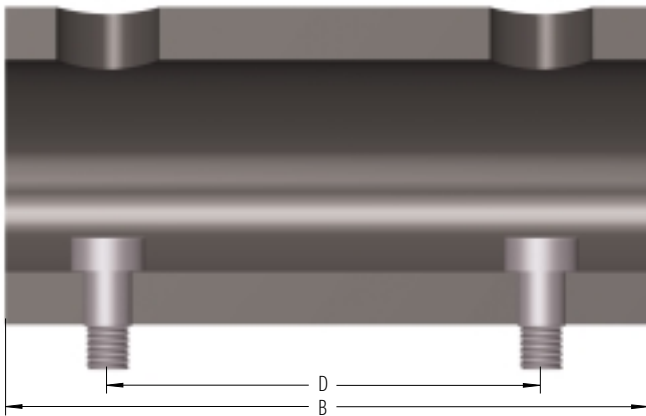

Ordering Example **TR 66-40L-2**

Type (Tubus radial long) ↑ ↑ ↑ ↑
 Outer - \varnothing (66 mm) ↑ ↑ ↑ ↑
 Stroke (40 mm) ↑ ↑ ↑ ↑
 Length 2 = 305 mm ↑ ↑ ↑ ↑

The calculation and selection of the required Profile Damper should be carried out or be approved by ACE.

Dimensions and Capacity Data

Type	W ₃ max Nm/cycle	Reaction force in N	Stroke	A	B	C	D	M	L ₁	L ₂	Weight in kg
TR 66-40L-1	100	6800	40	66	152	87	102	M 8	8	59	0,25
TR 66-40L-2	200	13600	40	66	305	87	254	M 8	8	59	0,55
TR 66-40L-3	300	20400	40	66	457	87	406	M 8	8	59	0,80
TR 66-40L-4	400	27200	40	66	610	87	559	M 8	8	59	1,10
TR 66-40L-5	500	34000	40	66	762	87	711	M 8	8	59	1,30
TR 76-45L-1	135	7200	45	76	152	100	102	M 8	8	68	0,35
TR 76-45L-2	270	14500	45	76	305	100	254	M 8	8	68	0,70
TR 76-45L-3	400	21700	45	76	457	100	406	M 8	8	68	1,10
TR 76-45L-4	535	29000	45	76	610	100	559	M 8	8	68	1,40
TR 76-45L-5	670	36300	45	76	762	100	711	M 8	8	68	1,70
TR 83-48L-1	155	8100	48	83	152	106	102	M 8	8	73	0,45
TR 83-48L-2	315	16300	48	83	305	106	254	M 8	8	73	0,90
TR 83-48L-3	470	24500	48	83	457	106	406	M 8	8	73	1,35
TR 83-48L-4	625	32600	48	83	610	106	559	M 8	8	73	4,80
TR 83-48L-5	780	40800	48	83	762	106	711	M 8	8	73	2,25
TR 99-60L-1	205	13600	60	99	152	130	102	M 16	16	88	0,60
TR 99-60L-2	410	27200	60	99	305	130	254	M 16	16	88	1,10
TR 99-60L-3	615	40800	60	99	457	130	406	M 16	16	88	1,75
TR 99-60L-4	820	54400	60	99	610	130	559	M 16	16	88	2,35
TR 99-60L-5	1025	68100	60	99	762	130	711	M 16	16	88	2,90
TR 99-60L-6	1230	81700	60	99	914	130	864	M 16	16	88	3,50
TR 99-60L-7	1435	95300	60	99	1067	130	1016	M 16	16	88	4,10
TR 143-86L-1	575	31700	86	143	152	191	102	M 16	16	127	1,25
TR 143-86L-2	1155	63500	86	143	305	191	254	M 16	16	127	2,50
TR 143-86L-3	1730	95300	86	143	457	191	406	M 16	16	127	3,80
TR 143-86L-4	2305	127100	86	143	610	191	559	M 16	16	127	5,10
TR 143-86L-5	2880	158900	86	143	762	191	711	M 16	16	127	6,40
TR 143-86L-6	3455	190600	86	143	914	191	864	M 16	16	127	7,70
TR 143-86L-7	4030	224000	86	143	1067	191	1016	M 16	16	127	9,00
TR 188-108L-1	1350	40800	108	188	152	245	102	M 16	16	165	2,15
TR 188-108L-2	2710	81700	108	188	305	245	254	M 16	16	165	4,45
TR 188-108L-3	4060	122500	108	188	457	245	406	M 16	16	165	6,70
TR 188-108L-4	5420	163400	108	188	610	245	559	M 16	16	165	9,00
TR 188-108L-5	6770	204300	108	188	762	245	711	M 16	16	165	11,20
TR 188-108L-6	8120	245100	108	188	914	245	864	M 16	16	165	13,45
TR 188-108L-7	9480	286000	108	188	1067	245	1016	M 16	16	165	15,75

The Profile damper Type TC from the innovative ACE TUBUS Series is a maintenance free, self-contained Damping element made from a special Co-Polyester Elastomer. They have been specially developed for Crane equipment applications and fulfill the international Industry standards OSHA and CMAA.

Many Crane applications require a spring rate with a high return force. This is achieved with the unique **Dual-Profile Concept** of the TC - S models. For Energy-Management-Systems the TC model types provide a cost efficient solution with a high return force capability.

The very small and light package size from \varnothing 64 mm up to \varnothing 176 mm covers an Energy absorption capacity ranging from 450 Nm up to 12,700 Nm /cycle. The excellent resistance to UV, seawater chemical and microbe attack together with the wide operating temperature range from -40°C to 90°C enables a wide range of applications.

Life expectancy is extremely high ; **up to twenty times** longer than for urethane dampers, **up to ten times** longer than rubber buffers and **up to five times** longer than steel springs.



Overload Capacity : For emergency use only (1 cycle) it is possible to exceed the W3 rating by + 40%.

Environment : Resistant to oil, grease, seawater and to microbe or chemical attack. Excellent UV and ozone resistance. Material does not absorb water or swell.

Dynamic Force range : 80,000 N to 978,000 N

Temperature range:
 -40°C to 90°C

Energy Absorption: 31 % to 63 %

Mounting: in any position

Impact velocity range :
up to max. 5 m/s

Mounting screw torque :

M12: 85 Nm

M16: 210 Nm

On request: special strokes, -characteristics, -spring rates, - sizes and materials.

Calculation and Selection to be approved by ACE.



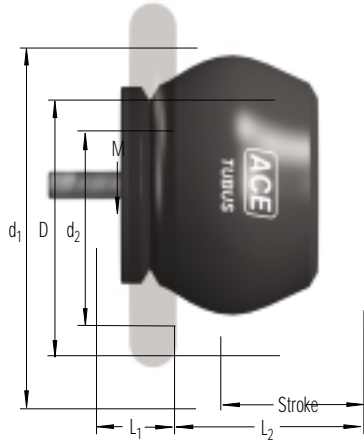

Model type TC

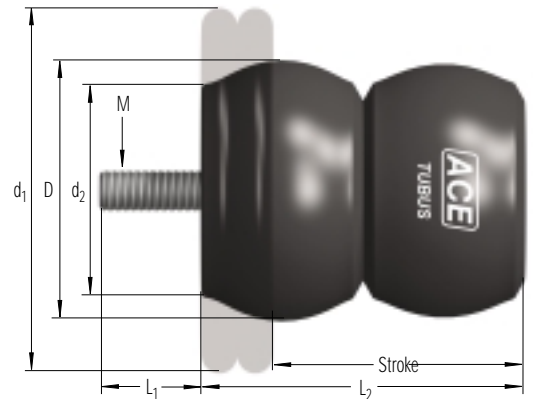

Model type TC-S

Ordering Example TC 90-49-S

Type (Tubus Crane Buffer) ↑ ↑ ↑ ↑
 Outer -ø (90 mm) ↑ ↑ ↑ ↑
 Stroke (49 mm) ↑ ↑ ↑ ↑
 Model type (soft) ↑ ↑ ↑ ↑

The calculation and selection of the required Profile Damper should be carried out or be approved by ACE.

Dimensions and Capacity Data

Type	*W ₃ max Nm/cycle	Stroke	D	L1	M	L2	d ₁	d ₂	Weight in kg
TC 64-62-S	450	62	64	12	M 12	79	89	52	0,2
TC 74-76-S	980	76	74	12	M 12	96	114	61	0,25
TC 83-73-S	1900	73	83	12	M 12	94	127	69	0,3
TC 86-39	1210	39	86	12	M 12	56	133	78	0,25
TC 90-49	1630	49	90	12	M 12	68	124	67	0,25
TC100-59	1770	59	100	12	M 12	84	149	91	0,5
TC 102-63	1970	63	102	16	M 16	98	140	82	0,5
TC 108-30	1900	30	108	12	M 12	53	133	77	0,35
TC 117-97	3710	97	117	16	M 16	129	188	100	1,0
TC 134-146-S	7290	146	134	16	M 16	188	215	117	1,6
TC 136-65	4250	65	136	16	M 16	106	178	106	1,1
TC 137-90	6350	90	137	16	M 16	115	216	113	1,1
TC 146-67-S	8330	67	146	16	M 16	118	191	99	1,5
TC 150-178-S	8860	178	150	16	M 16	241	224	132	2,6
TC 153-178-S	7260	178	153	16	M 16	226	241	131	2,3
TC 168-124	10100	124	168	16	M 16	166	260	147	2,3
TC 176-198-S	12720	198	176	16	M 16	252	279	150	3,6

* Max. Energy capacity per cycle for continuous use . For emergency use only (1 cycle) it is possible to exceed this rating by + 40 %

Characteristics

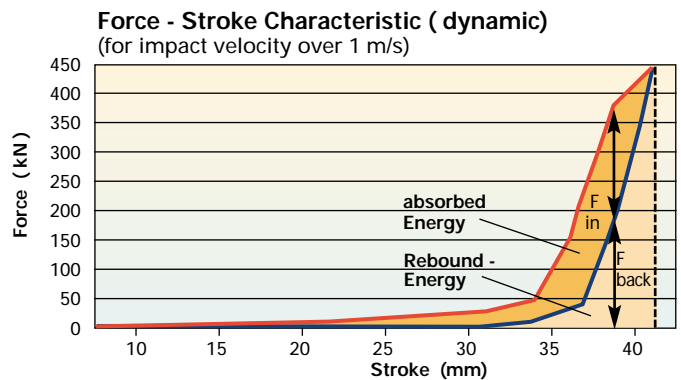
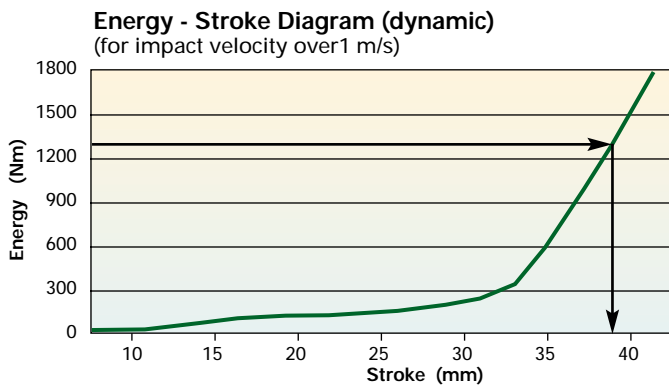

With the aid of the characteristic curves above you can estimate the proportion of the total energy that will be absorbed. Example :With impact energy of 1300 Nm the Energy-Stroke diagram shows that a stroke of about 38 mm is needed. On the Force-Stroke diagram you can estimate the proportion of absorbed energy to rebound energy at this stroke length.

Note: with these types the return force towards the end of the stroke is significant and we recommend you try to use a minimum of 90% of the total stroke available.

Force characteristics are similar for all sizes. Examples above are for Model TC 90-49-S. (Static characteristics for impact velocities under 0.5 m/s are available on request.)

Application Types

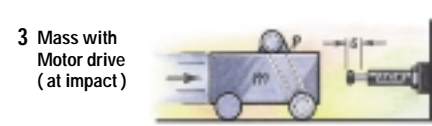
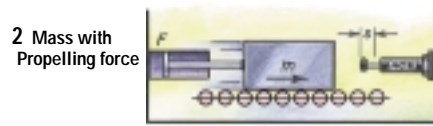
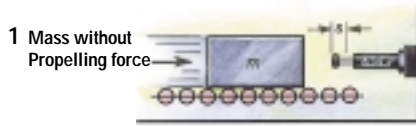

2.1 for vertical motion upwards
2.2 for vertical motion downwards

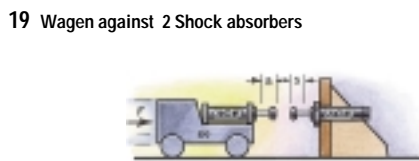
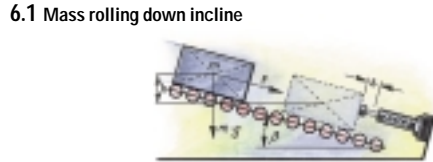
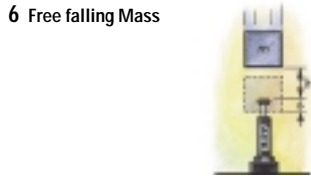

Case 1 Case 2 Case 3 Case 6 Case 6.1 Case 10 Case 19 Case 20 Case 21

For additional Formulae see the Main ACE catalogue pages 12-14.

Desired Damping type :

linear degressive progressive Q max. Reaction Force in N _____

Input Data :

- 1. Mass to be decelerated m = _____ kg
- 2. Impact velocity vd = _____ m/s
- 3. Propelling Force F = _____ N
- 4. Cycles per hour x = _____ 1/h
- 5. Other comments _____

Special requirements _____ Quantity/Year : _____
 _____ Machine Type _____

Sender :
 Company _____ Name/Pos. _____
 Address _____ Telephone _____
 _____ Fax _____
 _____ E-Mail _____

Please copy , fill out and fax to : Fax-No. 01925 - 229323