

piCLASSIC Pi48-3

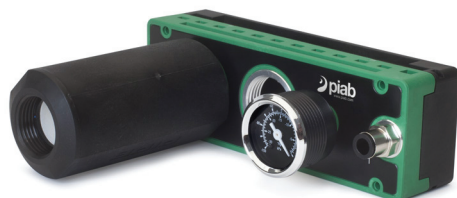

- ▶ Patented COAX® technology inside – the most energy efficient ejector technology.
- ▶ High performance reliability in cases of fluctuating or low compressed air pressure.
- ▶ Deep vacuum level achieved at very low feed pressure, 0.3 MPa.
- ▶ Fluctuating compressed air is commonplace in large plants and when the compressor has a high degree of utilization.
- ▶ Large capacity range, available with 1 to 6 COAX® Pi48 three-stage cartridges. A smaller piCLASSIC can easily be upgraded with more capacity if needed.
- ▶ Low-weight, configurable and modular design.
- ▶ Easy disassembly for maintenance.

Technical data

Description	Unit	Value
Feed pressure, optimum	MPa	0.30
Feed pressure, max.	MPa	0.7
Max. vacuum	-kPa	90
Internal volume, vacuum chamber, 1-2 cartridges	cm ³	140
Internal volume, vacuum chamber, 3-4 cartridges	cm ³	246
Internal volume, vacuum chamber, 5-6 cartridges	cm ³	353
Noise level at 40 -kPa & optimal feed pressure	dBA	65-68
Temperature range	°C	-10-80
Materials		PA, Al, SS, NBR (FKM), CuZn

Technical data, specific

Weight	Value (g)
1-2 cartridges	500-550
3-4 cartridges	720-790
5-6 cartridges	795-875
Silencer	120
Vacuum gauge	50

Vacuum flow at recommended feed pressure (0.30 MPa)

COAX® cartridge	Air consumption NI/s	Vacuum flow (NI/s) at different vacuum levels (-kPa)								
		0	10	20	30	40	50	60	70	80
Pi48-3 x1	2.0	5.6	2.5	1.8	1.1	0.65	0.50	0.35	0.25	0.10
Pi48-3 x2	4.0	11.2	5.0	3.6	2.2	1.3	1.0	0.70	0.50	0.20
Pi48-3 x3	6.0	16.8	7.5	5.4	3.3	1.95	1.5	1.05	0.75	0.30
Pi48-3 x4	8.0	22.4	10.0	7.2	4.4	2.6	2.0	1.4	1.0	0.40
Pi48-3 x5	10.0	23.8	11.3	8.6	5.5	3.25	2.5	1.75	1.25	0.50
Pi48-3 x6	12.0	26.9	12.8	10.3	6.6	3.9	3.0	2.1	1.5	0.60

Evacuation time at recommended feed pressure (0.30 MPa)

COAX® cartridge	Air consumption NI/s	Evacuation time (s/l) to reach different vacuum levels (-kPa)								
		10	20	30	40	50	60	70	80	90
Pi48-3 x1	2.0	0.020	0.060	0.12	0.25	0.45	0.70	1.0	1.6	4.0
Pi48-3 x2	4.0	0.010	0.030	0.06	0.13	0.23	0.35	0.50	0.80	2.0
Pi48-3 x3	6.0	0.007	0.020	0.04	0.08	0.15	0.23	0.33	0.53	1.33
Pi48-3 x4	8.0	0.005	0.015	0.03	0.06	0.11	0.18	0.25	0.40	1.0
Pi48-3 x5	10.0	0.004	0.012	0.024	0.05	0.09	0.14	0.20	0.32	0.80
Pi48-3 x6	12.0	0.003	0.010	0.023	0.04	0.08	0.12	0.17	0.27	0.67

Ordering information

1. Housing		piCLASSIC Code
Housing		PCL
2a. COAX® cartridge modules		piCLASSIC Code
A	COAX® cartridge module Pi48-3x1	P1
A	COAX® cartridge module Pi48-3x2	P2
B	COAX® cartridge module Pi48-3x3	P3
B	COAX® cartridge module Pi48-3x4	P4
C	COAX® cartridge module Pi48-3x5	P5
C	COAX® cartridge module Pi48-3x6	P6
2b. Valve Configuration		piCLASSIC Code
a	Standard	B
b	Non-return valve	A
2c. Sealing material		piCLASSIC Code
Nitrile		N
Viton		V
3. Function		piCLASSIC Code
Standard		S
4a. Compressed air connection		piCLASSIC Code
G1/4" female		A
1/4" NPT female		E
1/8" NPSF (G) female		D
*Push-in 8 mm (5/32")-1/4" female		08
*Push-in 10 mm-1/4" female		10
*Push-in 12 mm-1/4" female		12
<i>*Compressed air push-in connector included separately.</i>		
4b. Vacuum connection		piCLASSIC Code
G3/4" female		D
3/4" NPT female		E
G1" female		B
5. Accessory		piCLASSIC Code
None		X
Silencer G1" male		S
Vacuum gauge		V
Silencer G1" male & vacuum gauge		SV
Example		Ordering number
piCLASSIC Pi48-3x1, Standard Valve, Nitrile Sealing, Function Standard, Connections Comp. Air G1/4" female--Vacuum G3/4" female, Silencer G1" male & vacuum gauge		PCL.P1BN.S.AD.SV

Vacuum pumps/generators Medium



Dimensional drawing for piCLASSIC Pi48-3

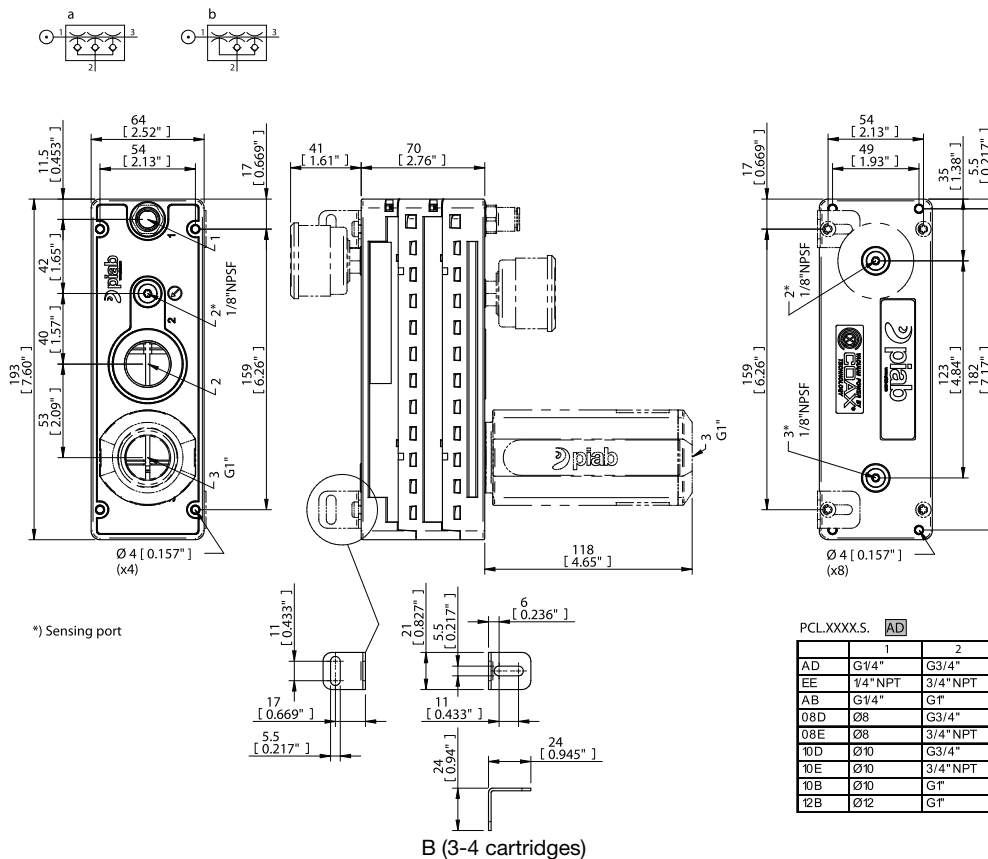
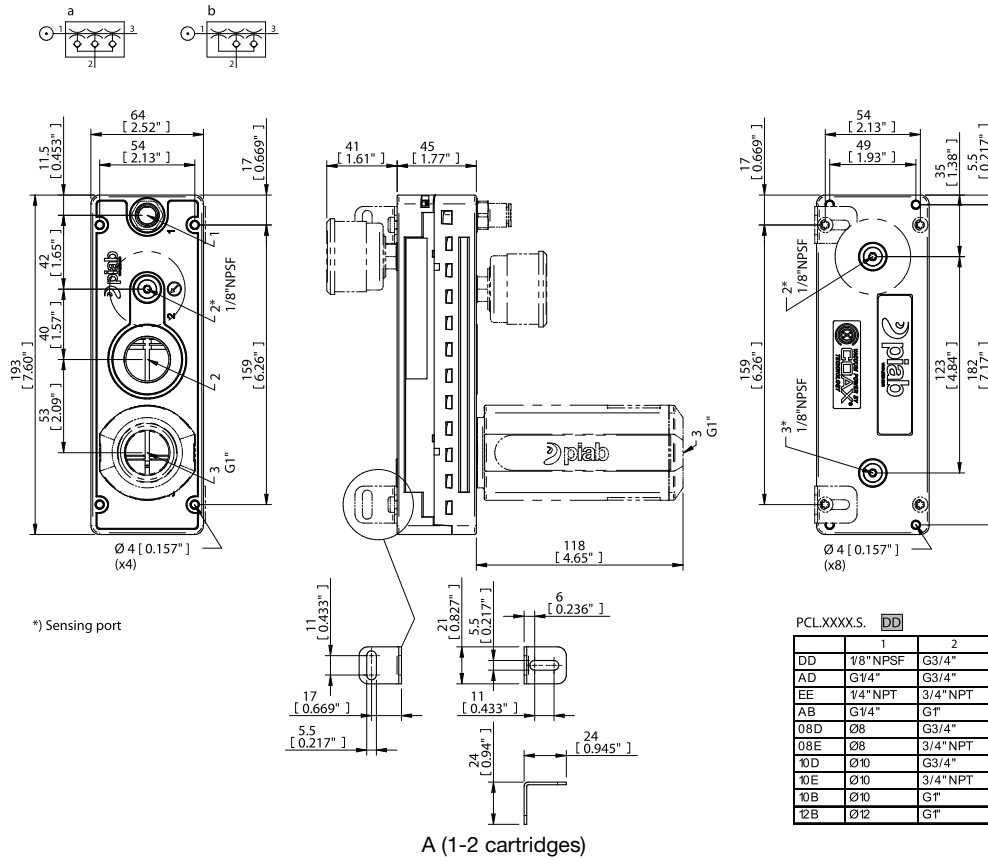

Vacuum pumps/generators Medium



Dimensional drawing for piCLASSIC Pi48-3

