

piINLINE™ MICRO



piINLINE™ Patent Pending

- ▶ Patented COAX® cartridge technology.
- ▶ High vacuum flow capacity in relation to energy consumption.
- ▶ Low weight inline design with push-in fittings.
- ▶ Quick and easy installation directly on the hose.
- ▶ Si/Ti cartridge at 0.6 MPa for extra vacuum flow.
- ▶ Bi cartridge for reliability at low feed pressures.
- ▶ Ti/Xi cartridge at 0.4/0.5 MPa when high flow and deep vacuum is needed.

TECHNICAL DATA

Description	Unit	Value
Feed pressure, max.	MPa	0.7
Material		PA, NBR, SS, CuZn
Temperature range	°C	-10-80

TECHNICAL DATA, SPECIFIC

Description	Unit	Value					
		Bi4-4	Xi4-4	Si6-6	Bi6-6	Ti6-6	Xi6-6
Noise level, min-max	dBA	64-73	70-76	67-73	67-73	74-85	70-76
Weight	g	16.9	16.9	9.8	9.8	9.8	9.8
Connection, vacuum	mm	4	4	6	6	6	6
Connection, compressed air	mm	4	4	6	6	6	6

VACUUM FLOW

COAX® Cartridge	Feed pressure MPa	Air consumption NI/s	Vacuum flow (NI/s) at different vacuum levels (-kPa)									Max vacuum -kPa
			0	10	20	30	40	50	60	70	80	
Si	0.6	0.12	0.28	0.21	0.12	0.08	0.07	0.06	0.04	0.02	—	75
Ti	0.6	0.37	0.31	0.27	0.24	0.20	0.15	0.09	0.04	0.01	—	75
Bi	0.18	0.14	0.23	0.15	0.060	0.040	0.035	0.023	0.013	0.006	—	83
Ti	0.4	0.27	0.32	0.28	0.23	0.17	0.10	0.07	0.04	0.02	0.004	84
Xi	0.5	0.13	0.24	0.17	0.10	0.06	0.04	0.03	0.02	0.01	0.01	92

EVACUATION TIME

COAX® Cartridge	Feed pressure MPa	Air consumption NI/s	Evacuation time (s/l) to reach different vacuum levels (-kPa)								Max vacuum -kPa
			10	20	30	40	50	60	70	80	
Si	0.6	0.12	0.41	1.01	2.01	3.30	4.90	6.90	10.2	—	75
Ti	0.6	0.37	0.30	0.70	1.20	1.80	2.60	4.20	8.43	—	75
Bi	0.18	0.14	0.50	1.40	3.90	6.40	10.0	16.0	28.0	51.0	83
Ti	0.4	0.27	0.33	0.73	1.20	2.00	3.10	5.00	8.30	16.6	84
Xi	0.5	0.13	0.49	1.23	2.48	4.50	7.30	11.3	18.0	28.0	92

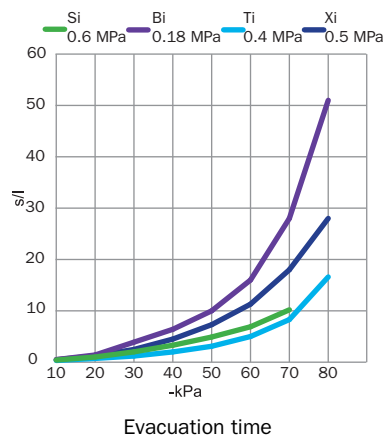
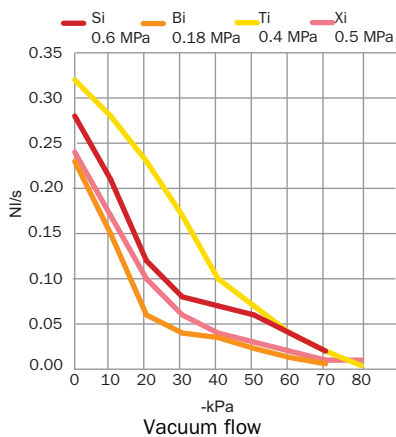

ORDERING INFORMATION

	Description	Art. No.	ECW	ACW
B	piINLINE™ vacuum generator MICRO Bi, 4-4 mm	0122880	v	v
B	piINLINE™ vacuum generator MICRO Xi, 4-4 mm	0122881	v	v
A	piINLINE™ vacuum generator MICRO Si, 6-6 mm	0122882	v	v
A	piINLINE™ vacuum generator MICRO Bi, 6-6 mm	0122883	v	v
A	piINLINE™ vacuum generator MICRO Ti, 6-6 mm	0122022	v	v
A	piINLINE™ vacuum generator MICRO Xi, 6-6 mm	0122884	v	v

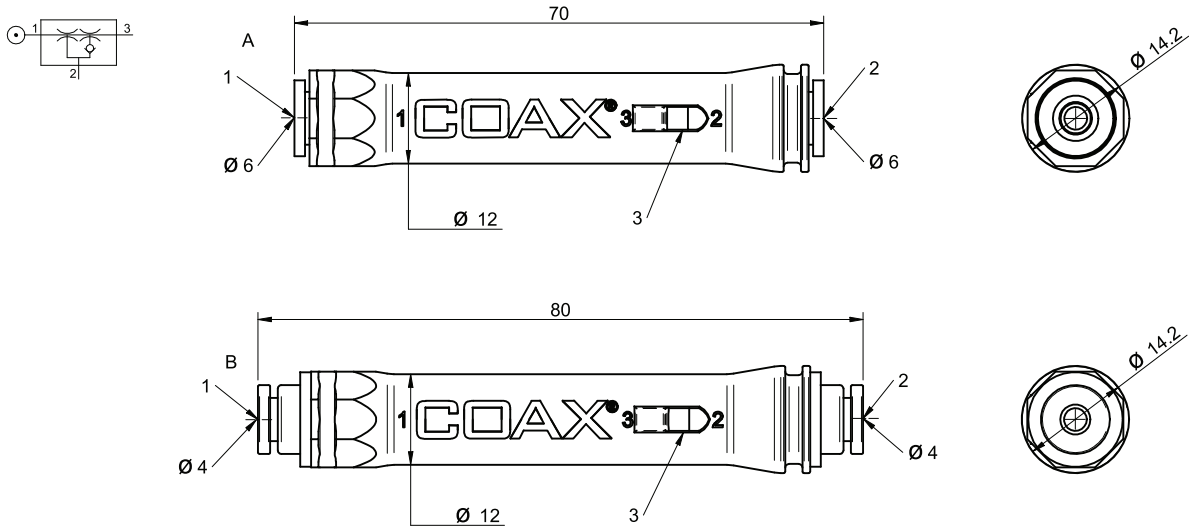

Vacuum generators
SMALL

ORDERING INFORMATION, ACCESSORIES

Description	Art. No.	ECW	ACW
Snap-in piINLINE™ 5x MICRO mounting bracket	0123093	v	v

v = Available in European Central Warehouse (ECW) / Asian Central Warehouse (ACW).