

BIG-PLUS SPINDLE SYSTEM ASSURES HIGHER RIGIDITY AND ACCURACY OF TOOLHOLDERS IN HIGH SPEED AND DIFFICULT MACHINING APPLICATIONS

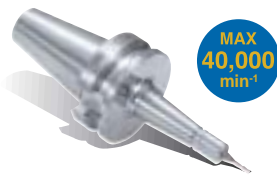

MEGA MICRO CHUCK PAT. MEGA NEW BABY CHUCK PAT. MEGA E CHUCK PAT. MEGA DOUBLE POWER CHUCK PAT.



MAX 40,000 min⁻¹

To suit micro drills & end mills

Clamping range: ø0.45 to ø6.05mm



MAX 40,000 min⁻¹

To suit end mills, drills, taps, reamers & etc.

Clamping range: ø0.25 to ø20mm



MAX 40,000 min⁻¹

To suit end mills

Clamping range: ø3 to ø12mm



MAX 30,000 min⁻¹

To suit end mills

Clamping range: ø16 to ø50mm

MOLD CHUCK PAT.



Side Lock Holder for Mold Making
Clamping range: ø3 to ø20mm

CK BORING SYSTEM
BIG + KAISER



Especially effective in large or deep boring applications, as well as long reach applications.

FULLCUT MILL



Type FCR
Integral endmill with excellent cutting performance.

FACE MILL ARBOR



Eliminates chatter for smoother finish

ANGLE HEAD



Wide range of compact heads suitable for all kinds of applications.

HIGH SPINDLE (GTG)



Spindle speed increase with planetary gears system.

AIR TURBINE SPINDLE



High Precision Micro-Machining with Air Power.

DYNA TEST (Test Arbor)



High Precision Maintenance of machine's accuracy test bar

Cleaning Tools

For maintaining accuracy, it is recommended that the machine spindle taper and flange be cleaned regularly.

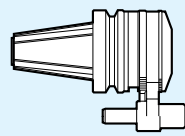

<BIG> AUTO CLEANER

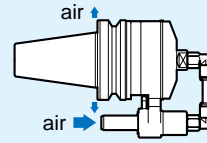

<BIG> FACE CLEANER

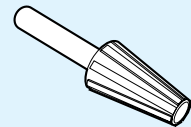

<BIG> SPINDLE CLEANER

WHEN ORDERING BIG-PLUS TOOLHOLDERS

BIG-PLUS SPINDLE SYSTEM can be applied to most BIG toolholders. When ordering, please add "B" at the beginning of model numbers.

Example: **DV40(DIN69871)**
BT50(JIS-BT)



BDV40
BBT50

To benefit from all the technical advantages which the BIG-PLUS Spindle System offers, one must have a machining center which is equipped with the BIG-PLUS spindle and utilize BIG-PLUS toolholders.



BIG DAISHOWA SEIKI CO LTD

Takaramachi 5-2, Higashiosakashi
Osaka 579-8025 JAPAN
Phone : (+81)-72-982-8277 Fax : (+81)-72-982-8370
http://www.big-daishowa.com E-mail: export@big-net.ne.jp



JQA-QMA11602
AWAJI No.1 Factory
JQA-QM3913
FA Dept.

CATALOG No.EXm48-2-0807-1

Subject to technical changes by further developments.



PATENTED : U.S.A., CANADA, GERMANY, U.K., FRANCE, ITALY & SOUTH KOREA

BIG DAISHOWA SEIKI CO LTD

CATALOG No. **EXm48-2**

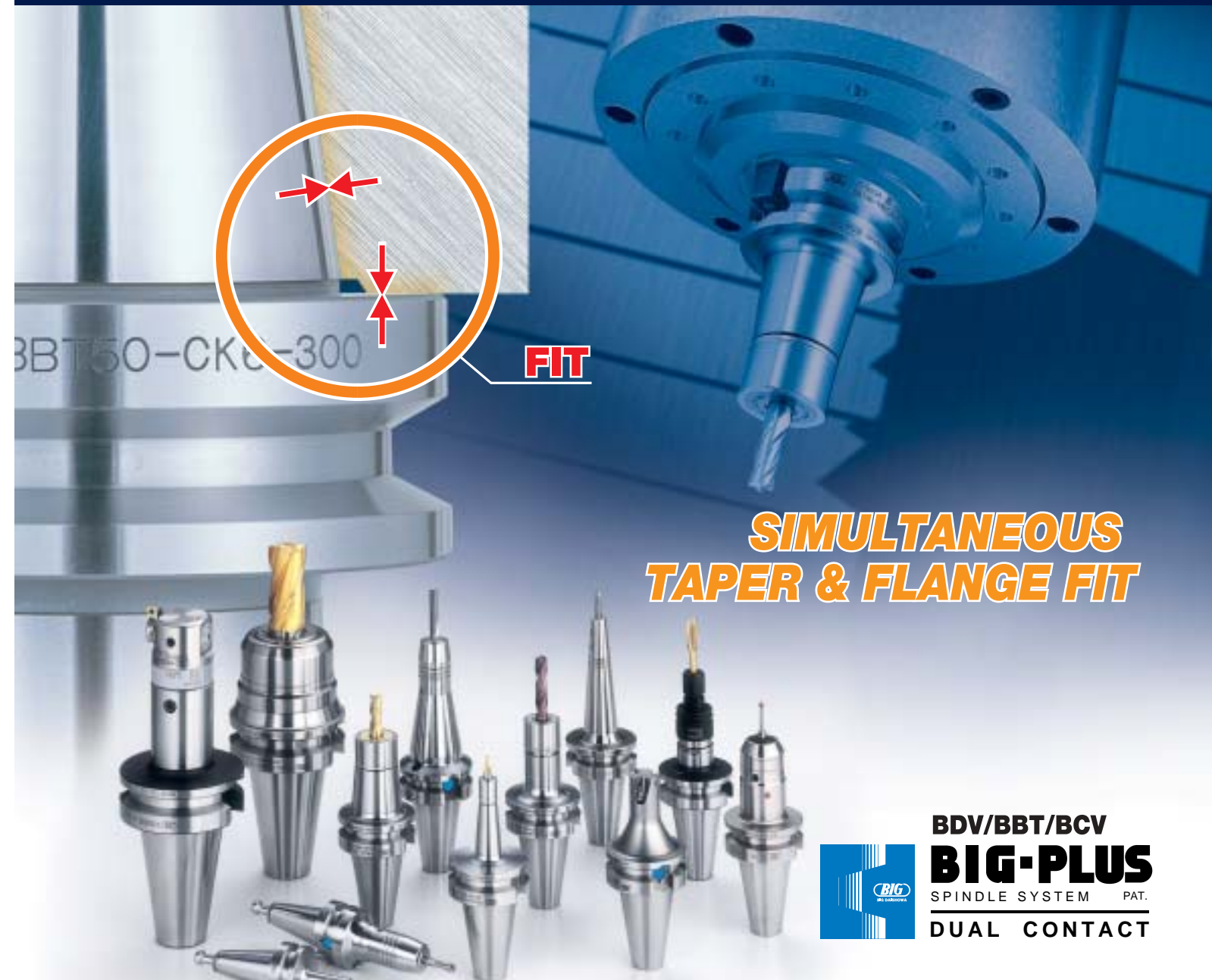

SIMULTANEOUS TAPER & FLANGE FIT

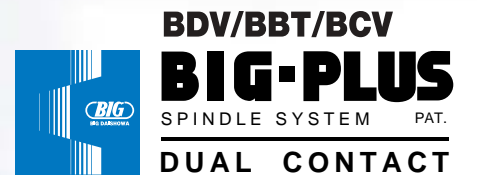

Simultaneous fit system surpasses all other spindle concepts while offering interchangeability with existing machines and toolholders.

SIMULTANEOUS DUAL CONTACT SYSTEM MAINTAINS INTERCHANGEABILITY WITH EXISTING STANDARDS

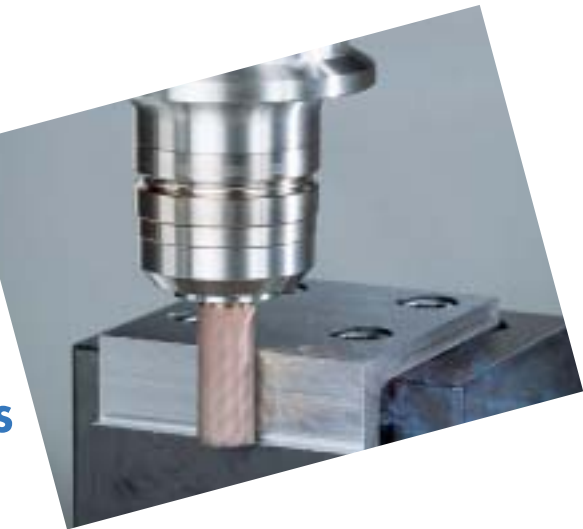

INTERCHANGEABLE WITH EXISTING STANDARDS COST SAVING DUAL CONTACT SYSTEM

BIG-PLUS is a simple Simultaneous Dual Contact Spindle System maintaining interchangeability with existing machines and toolholders.

BASIC CONCEPT

The BIG-PLUS Spindle System offers simultaneous dual contact between the machine spindle face and toolholder flange face, as well as the machine spindle taper and long toolholder taper shank. This system is based on the most currently available standards for JIS-BT, DIN69871 and CAT-V Flange tooling.

Dual contact is achieved with the BIG-PLUS Spindle System by eliminating the gap or space which generally exists between the machine spindle face and the toolholder flange face. For example, in the case of BT30 and BT40 taper machines, this gap is approximately 2.0mm, and in the case of BT50 taper machines, this gap is approximately 3.0mm. BIG-PLUS toolholders are manufactured to have thicker flanges which eliminates half of the respective gap. By utilizing machines which have BIG-PLUS Spindles installed in them, the other half of the gap is eliminated since the machine spindle face has been extended out by the equivalent distance, depending on the respective taper. By having all tolerances strictly controlled by high tolerance gauges and measuring equipment, simultaneous dual contact of the face and taper is thus assured. This larger contact diameter to the spindle flange face area which the BIG-PLUS System provides results in remarkable improvement to rigidity and performance.

WORKING PRINCIPLE

Due to the pulling force on the pullstud, the spindle of the machine will expand from elastic deformation when the toolholder taper comes into contact with the machine spindle taper.

As a result, there will be axial movement of the toolholder after clamping of the pullstud. The axial movement is different on each model of machine depending on the external diameter, rigidity and clamping mechanism of the machine spindle. To determine the proper spindle nose dimensions and tolerances, the axial movement of the toolholder is very carefully measured by the licensed BIG-PLUS machine tool builder. In this way, the BIG-PLUS Spindle System skillfully utilizes the elastic deformation of the machine spindle to control the gauge line accuracy, which thus insures that dual contact of the face and taper is achieved.

Reference data

SPINDLE TAPER	PULLING FORCE	AXIAL MOVEMENT
#40	800kg	20 μm
#50	2,000kg	20 μm

The above pulling force and axial movement are different on each model of machine.

● INCREASED CONTACT DIAMETER(Example of BT)

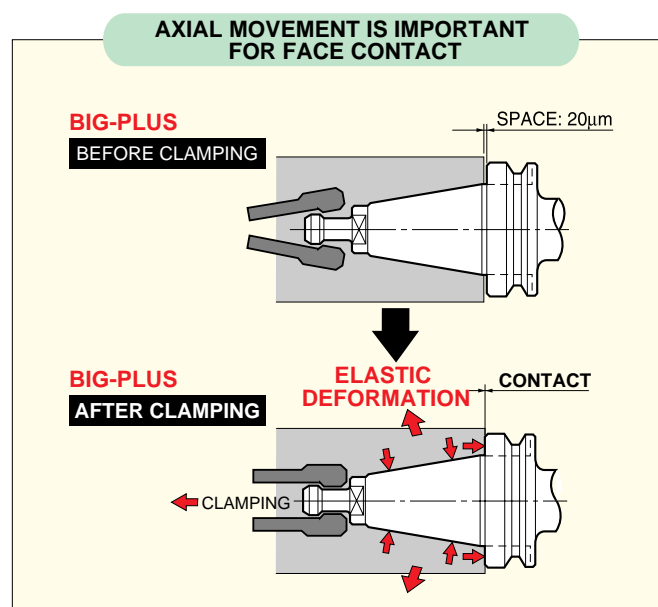
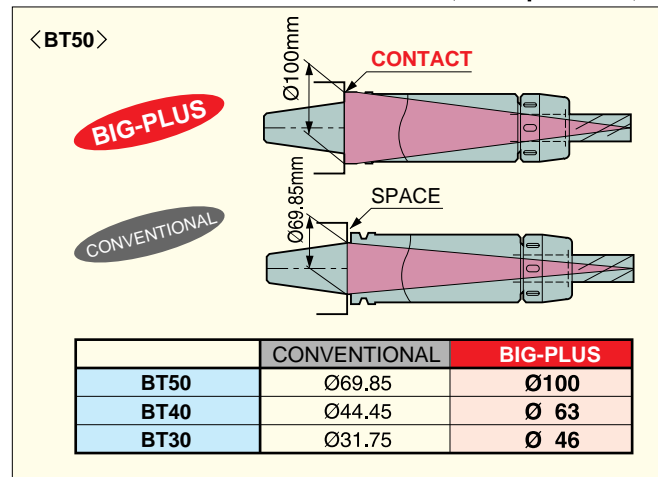

THERE ARE MANY ADVANTAGES AND BENEFITS!

Q Can existing machines and toolholders be used?

A PERFECT INTERCHANGEABILITY WITH EXISTING MACHINES AND TOOLHOLDERS

Yes, they can. BIG-PLUS holders can be used on existing standard machine spindles. Existing standard toolholders can also be used on BIG-PLUS spindles. In this case, simultaneous contact can not be attained. In order to achieve excellent performance of simultaneous contact, please use BIG-PLUS holders on BIG-PLUS spindles. Please be aware that simultaneous contact toolholders other than BIG-PLUS holders may damage BIG-PLUS spindles.

To benefit from all the technical advantages which the BIG-PLUS Spindle System offers, both a BIG-PLUS HOLDER and a BIG-PLUS Spindle are required.

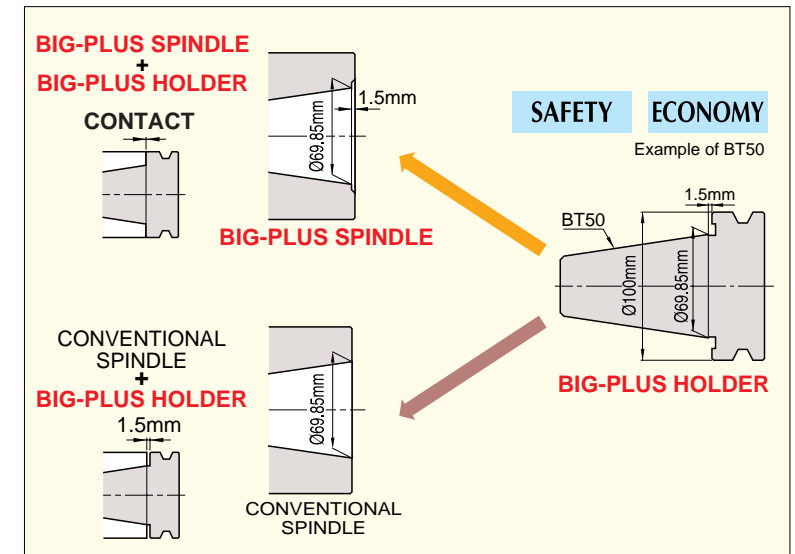

Q Are new accessories required?

A EXISTING ACCESSORIES UTILIZED

No, they are not. Existing accessories such as presetters, tooling fixtures and tooling storage systems can be used with BIG-PLUS toolholders. Further, it is not necessary to modify tool magazines and ATC devices of existing machines.

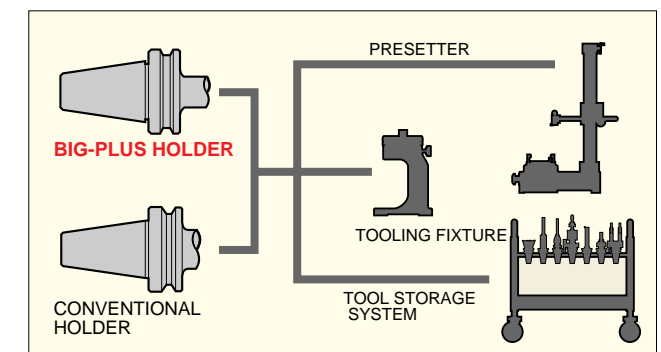

Q Is there any effect on the life of the machine spindle and toolholders?

A MINIMIZED VIBRATION PREVENTS FRETTING CORROSION

Yes, there is. One of the problems in heavy machining and high speed machining is the tarnishing in the taper portion of both the machine spindle and toolholder, which is called fretting corrosion. Fretting corrosion is a friction oxidation that develops when two contacting pieces of metal have movement as a result of machining vibration. BIG-PLUS protects the toolholders from this oxidation by reducing the machining vibration with the higher rigidity achieved by its dual contact method. This results in greatly extending the life of both the machine spindle and the toolholder.



Q What benefit can be expected at high spindle speeds?

A ELIMINATION OF Z-AXIAL MOVEMENT

At high rotational spindle speeds, the mouth of the machine spindle can expand slightly due to centrifugal force. As the machine spindle expands, the conventional toolholder, which is under constant draw bar pulling pressure, moves further into the spindle. On high tolerance applications, this slight pull back of the cutter can affect dimensional accuracy of the Z-axis. Pull back can also cause the toolholder to get locked into the machine spindle taper. The face contact provided by the BIG-PLUS Spindle System prevents the toolholder from being drawn back into the machine spindle.

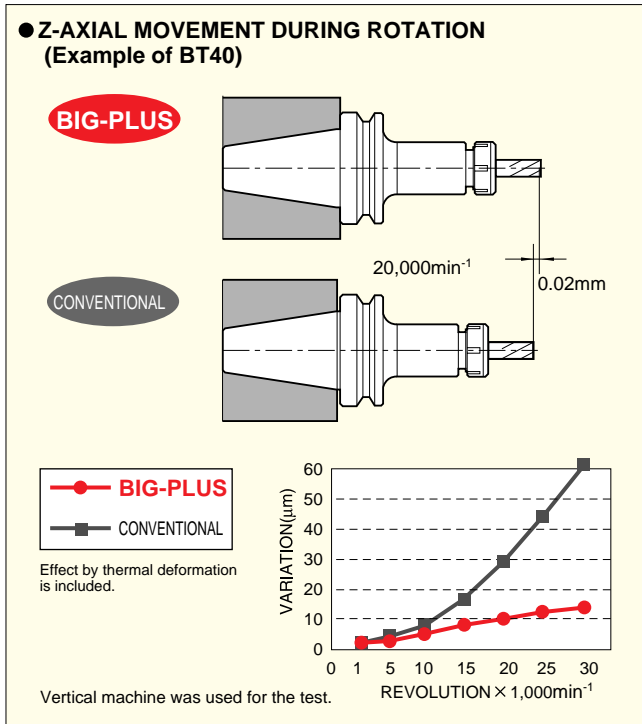

Q What effect will there be on machining results?

A MINIMIZED DEFLECTION FOR MAXIMUM MACHINING ACCURACY & SUPERIOR FINISH

With BIG-PLUS simultaneous contact, machining rigidity is greatly enhanced due to the larger contact diameter of the toolholder flange face. This larger face contact combined with the taper contact works together to resist deflection. With less deflection, greater machining accuracy and superior finish can be achieved.

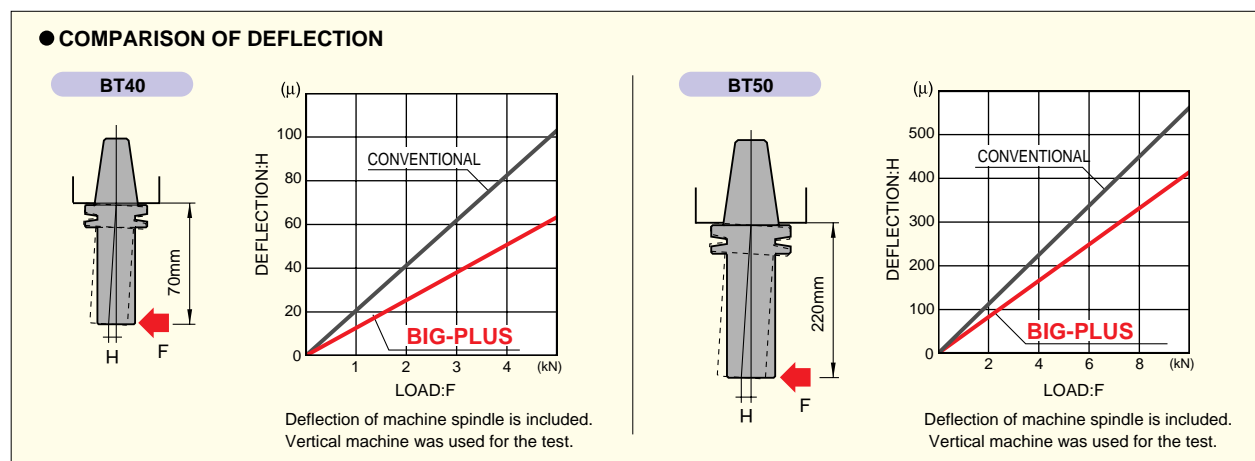

Q What influence is there on ATC (Automatic Tool Change) repeatability?

A TOOLHOLDER REPEATABILITY WHEN USING ATC WITHIN 1 MICRON

The BIG-PLUS System assures the highest precision location of the toolholder in the spindle when using the ATC for loading tools, as a result of the dual contact which precisely positions the toolholder within 1 micron.

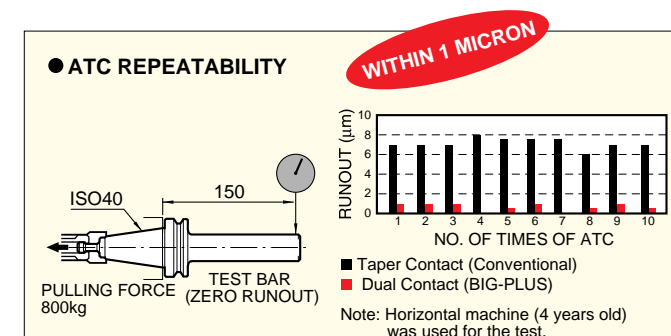

Q Is there any problem using BIG-PLUS toolholders on different BIG-PLUS machines?

A ULTRA HIGH TOLERANCE GAUGE CONTROLS GUARANTEE FULL INTERCHANGEABILITY

No, there is no problem. The BIG-PLUS Spindle System strictly dictates the dimensions of the spindle face of a machine and the flange face of a toolholder. These dimensions are controlled by exclusive high tolerance gauges and measuring equipment, so dual contact of the taper and face is guaranteed. Full interchangeability therefore exists between all BIG-PLUS machine spindles and BIG-PLUS toolholders.

Strict gauge controls for BIG-PLUS Spindles are maintained by the licensed Machine Builders.

[GAUGES FOR MACHINE SPINDLE]

MASTER GAUGE	MEASURING EQUIPMENT	MASTER ARBOR
Ring gauge as a reference dimension between the gauge line and spindle face.	For measuring the distance between the gauge line and the spindle face.	To measure axial movement of the holder.



These gauges are appropriate for CAT V-FLANGE, ANSI B5.50, JIS-BT, DIN69871 and ISO 7388/1.

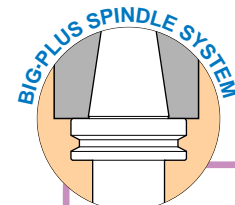

MACHINE BUILDERS

The BIG-PLUS Spindle System is offered by many of the world's leading manufacturers of machining centers. Some of the machine and spindle builders who have produced BIG-PLUS spindles are as follows;

ANCA, CHUO-SEIKI, CITIZEN, COLGAR, Cross Hüller, DMG, DIXI, D.S. TECHNOLOGIE, ENSHU, FANUC, FOREST-LINÉ GROUP, FPT, GIDDING&LEWIS, HONMA, HORKOS, HOWA, IBAG, IKEGAI, INOUE KOSOKU KIKAI, JTEKT, KARATSU, KASHIFUJI, KIRA, KITAMURA, KOMATSU, KONDIA, KOYO, KURAKI, LAZZATI, MAKINO SEIKI, MAKINO, MANDELLI, MATSUURA, MAZAK, MECTRON, MILLTRONICS, MITSUBISHI, MITSUBOSHI KOGYO, MITSUI SEIKI, MORI SEIKI, MOTOKUBO, NB, NIIGATA MACHINE TECHNO, NISSIN, NOMURA, NSK, NTC, OKK, OKUMA&HOWA, OKUMA, O-M, OMLAT, PAMA, REIDEN, SAJO, SANKYO SEIKI, SETCO, SHODA, SNK, SODICK, STUDER, SUGINO MACHINE, TAJMAC-ZPS, TAKISAWA, TANABE, TOSHIBA MACHINE, Tos Varnsdorf, TOYO SEIKI, TSUGAMI, UTUNOMIYA, YAMASAKI GIKEN, YASDA,

[As of AUGUST, 2007]

BIG-PLUS APPLICATION EXAMPLES

These application examples include valuable information collected from end users. We will be pleased if such examples will help you to improve your productivity.

- DRILLING**
Applications
P5
- END MILLING**
Applications
P5-P8
- BORING**
Applications
P9
- FACE MILLING**
Applications
P10

DRILLING Applications

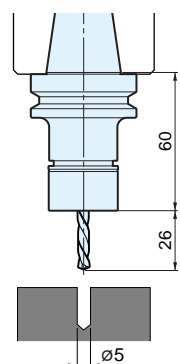

#40 Aluminum Improved Accuracy

CUTTING CONDITIONS	
MACHINE TOOL	BBT30 (4-axis-Machining Center)
TOOL HOLDER	(BIG) MEGA NEW BABY CHUCK BBT30-MEGA10N-60 BT30 (Collet chuck by other manufacturer)
CUTTER	φ5 solid carbide drill
WORK MATERIAL	Forged aluminum
SPINDLE SPEED	20,000 (min ⁻¹)
CUTTING SPEED	314 (m/min.)
FEED RATE	800 (mm/min.) 0.04 (mm/rev.)

RESULT	
Drill hole precision	
BIG-PLUS	Within 5μm
Other manufacturer	10 - 20μm

Precision of drilled hole is improved as a result of the superior repeatability during automatic tool changing.

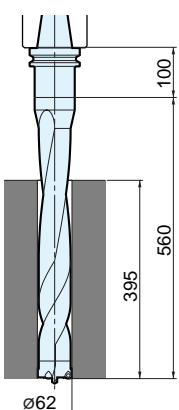
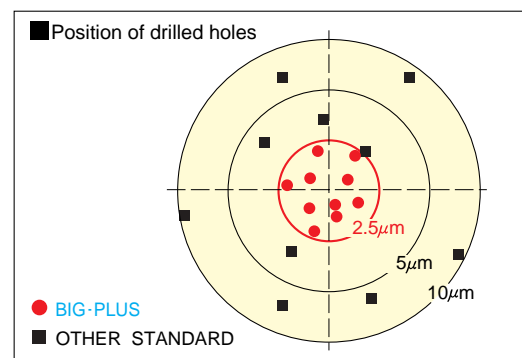

#50 Cast steel 2-times higher efficiency

CUTTING CONDITIONS	
MACHINE TOOL	BBT50 (Horizontal Machining Center)
TOOL HOLDER	BBT50-ABS80-100 (ABS Holder)
CUTTER	(BIG) Deep hole drill φ62×8D
WORK MATERIAL	SF590 steel forging
SPINDLE SPEED	670 (min ⁻¹)
CUTTING SPEED	130 (m/min.)
FEED RATE	70 (mm/min.) 0.105 (mm/rev.)

RESULT	
Drilling time per hole	
BIG-PLUS	5min and 30sec
Other manufacturer	12min and 30sec

The cutting efficiency is increased by 2 times.

END MILLING Applications

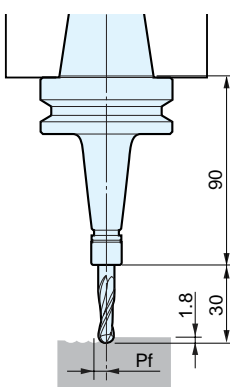

#40 Carbon steel

CUTTING CONDITIONS	
MACHINE TOOL	BBT40 (Vertical Machining Center)
TOOL HOLDER	(BIG) MEGA MICRO CHUCK BBT40-MEGA6S-90T BT40 (Collet chuck by other manufacturer)
CUTTER	φ6 carbide ball end mill
WORK MATERIAL	S50C(C50)
SPINDLE SPEED	12,000 (min ⁻¹)
FEED RATE	720 (mm/min.) 0.03 (mm/tooth)

● RESULT
BIG-PLUS and rigid taper design avoid chatter even with high peck feed milling leading to dramatically reduced machining time.

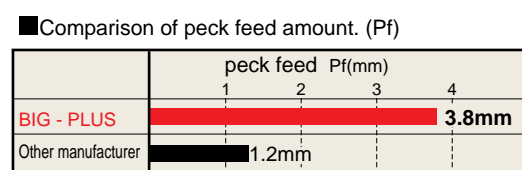

END MILLING Applications

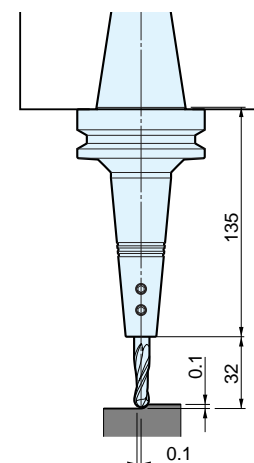

#40 Aluminum

CUTTING CONDITIONS	
MACHINE TOOL	BBT40 (Horizontal Machining Center) MAX 15,000(min ⁻¹)
TOOL HOLDER	(BIG) MOLD CHUCK BBT40-SSL8-135 BT40-SSL8-135
CUTTER	R4 2-flute carbide ball end mill
WORK MATERIAL	A2017 Duralumin
SPINDLE SPEED	8,000 · 12,000 · 15,000 (min ⁻¹)
FEED RATE	0.1 (mm/tooth)
CUTTING DEPTH	0.1 (mm)
PECKING AMOUNT	0.1 (mm)

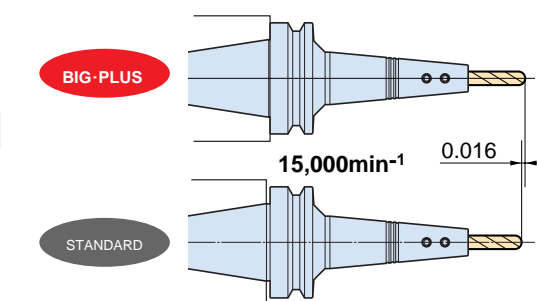
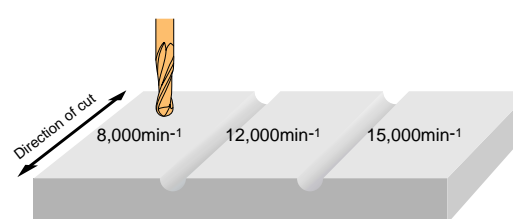
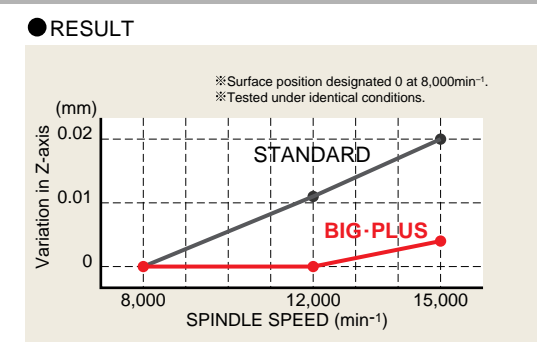

As the spindle speed increases then Z length changes with the standard holder when compared with BIG-PLUS until at 15,000min⁻¹ the difference is 0.016mm.

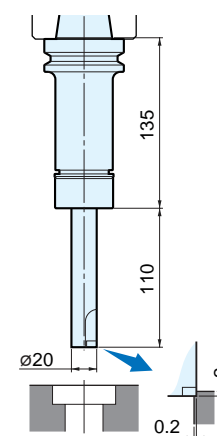

#40 Aluminum Improved concentricity within 5μm

CUTTING CONDITIONS	
MACHINE TOOL	BBT40 (Horizontal Machining Center)
TOOL HOLDER	(BIG) MEGA NEW BABY CHUCK BBT40-MEGA20N-135
CUTTER	φ20 End mill brazed with diamond (2 cutting edges)
WORK MATERIAL	Cast aluminum
SPINDLE SPEED	10,000 (min ⁻¹)
CUTTING SPEED	628 (m/min.)
FEED RATE	1,000 (mm/min.) 0.05 (mm/tooth)

● RESULT
Concentricity of contouring was improved within 5μm.

#40 Stainless steel

CUTTING CONDITIONS	
MACHINE TOOL	BBT40 (Vertical Machining Center)
TOOL HOLDER	(BIG) MEGA NEW BABY CHUCK BBT40-MEGA13N-90
CUTTER	φ6 carbide ball end mill
WORK MATERIAL	X5CrNiMo17-12-2
SPINDLE SPEED	15,000 (min ⁻¹)
FEED RATE	8,000 (mm/min.) 0.27 (mm/tooth)

● RESULT
There was no change in dimension in Z axis, and smooth finish surface was achieved. (surface roughness : less than Rmax 1.6μm).

BIG-PLUS APPLICATION EXAMPLES



END MILLING Applications

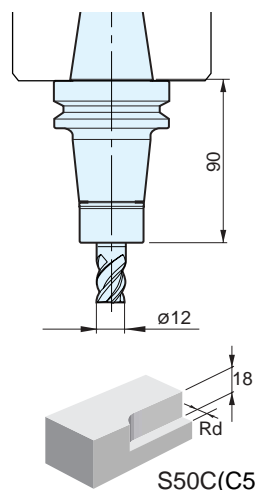

#40 Carbon steel

CUTTING CONDITIONS

MACHINE TOOL	BBT40 (Vertical Machining Center)
TOOL HOLDER	(BIG) MEGA E CHUCK BBT40-MEGA13E-90 BT40 (Collet chuck by other manufacturer)
CUTTER	∅12 carbide endmill (4 flutes)
WORK MATERIAL	S50C(C50)
SPINDLE SPEED	1,327 (min ⁻¹)
CUTTING SPEED	50 (m/min.)
FEED RATE	425 (mm/min.) 0.08 (mm/tooth)

● RESULT
5 times better cutting performance than other company.

Comparison of the max radial depth of cut

Radial depth of cut Rd (mm)	
	2 4 6 8 10 12
BIG-PLUS	12mm
Other manufacturer	2.5mm

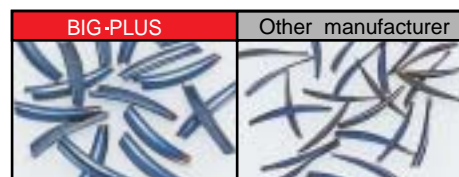

#40 Carbon steel

CUTTING CONDITIONS

MACHINE TOOL	BBT40 (Vertical Machining Center)
TOOL HOLDER	(BIG) MEGA DOUBLE POWER CHUCK BBT40-MEGA20D-75 BT40 (Milling chuck by other manufacturer)
CUTTER	∅20 carbide endmill (4 flutes)
WORK MATERIAL	S55C(C55)
SPINDLE SPEED	1,590 (min ⁻¹)
CUTTING SPEED	100 (m/min.)
FEED RATE	100 (mm/min.) 0.08 (mm/tooth)

RESULT

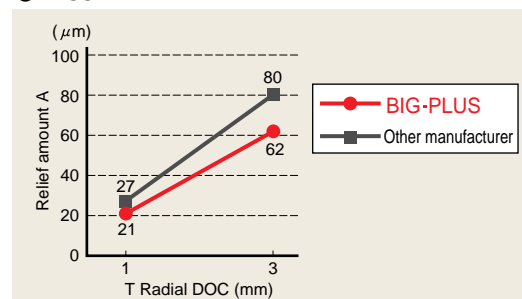

Increased rigidity minimizes deflection against cutting resistance and reduces cutting relief by 30%

Minimized relief

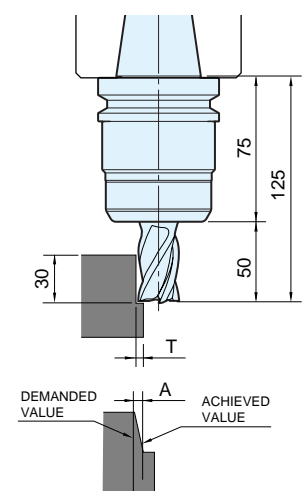

#50 Steel for structural

CUTTING CONDITIONS

MACHINE TOOL	BBT50 (Horizontal Machining Center)
TOOL HOLDER	(BIG) MEGA DOUBLE POWER CHUCK BBT50-MEGA32D-105 BT50 (Milling chuck by other manufacturer)
CUTTER	∅32 4-Flute Carbide End Mill
WORK MATERIAL	SS400 for general structure
SPINDLE SPEED	2,800 (min ⁻¹)
CUTTING SPEED	282 (m/min.)
FEED RATE	1,120 (mm/min.) 0.1 (mm/tooth)

● RESULT
Despite "L" being 15mm longer the BIG-PLUS holder (MEGA DOUBLE POWER CHUCK) achieves a 1.6 times improvement in metal removal rate.

BIG-PLUS	Other manufacturer
Depth of cut d=14mm	Depth of cut d=9.5mm
Metal removal 627cc/min	Metal removal 403cc/min

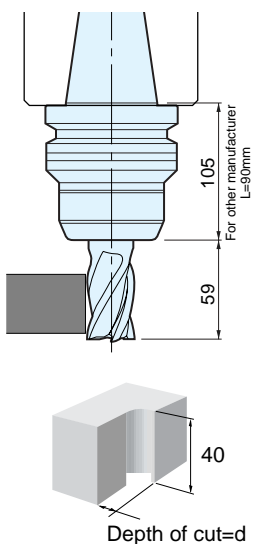

END MILLING Applications

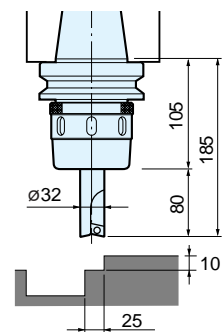

#50 Carbon steel

CUTTING CONDITIONS

MACHINE TOOL	BBT50 (Vertical Machining Center)
TOOL HOLDER	(BIG) NEW HI-POWER MILLING CHUCK BBT50-HMC32-105 BT50-HMC32-105
CUTTER	∅32 end mill with insert (2 cutting edges)
WORK MATERIAL	S55C(C55)
SPINDLE SPEED	1,080 (min ⁻¹)
CUTTING SPEED	110 (m/min.)
FEED RATE	250 (mm/min.) 0.12 (mm/tooth)
CUTTING DEPTH	25mm wide X 10mm deep

Cutting length until tool life	
	50 100
BIG-PLUS	100m
STANDARD	23m

Using a BIG-PLUS toolholder the improved concentricity accuracy increased the tool life to 4 times longer than a standard holder.

#40 Carbon steel

CUTTING CONDITIONS

MACHINE TOOL	BBT50 (Vertical Machining Center)
TOOL HOLDER	(BIG) SIDE LOCK HOLDER BBT50-SL50.8-121 BT50-SL50.8-121
CUTTER	∅40 ball end mill with insert
WORK MATERIAL	S55C(C55)
SPINDLE SPEED	800 (min ⁻¹)
CUTTING SPEED	100 (m/min.)
FEED RATE	300 (mm/min.) 0.19 (mm/tooth)
CUTTING DEPTH	25mm peck X 5mm deep

Cutting length until tool life	
	50 100 150 200 250 300
BIG-PLUS	300m
STANDARD	25m

Using BIG-PLUS holder, tool life was prolonged 12 times longer than a standard holder.

Extended tool life

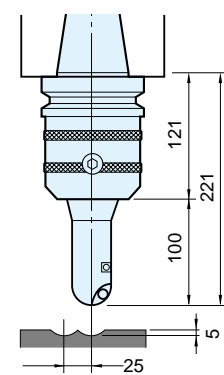

#40 Carbon steel

CUTTING CONDITIONS

MACHINE TOOL	BBT40 (Vertical Machining Center)
TOOL HOLDER	(BIG) FULL CUT MILL BBT40-FCM32113-85
INSERT	ARG321104(ACZ350) 3 cutting edges
WORK MATERIAL	S50C(C50)
SPINDLE SPEED	1,500 (min ⁻¹)
CUTTING SPEED	150 (m/min.)
FEED RATE	0.12 (mm/tooth)
DEPTH OF CUT	9 (mm)

● RESULT
In #40 taper machines, only FULLCUT MILL can achieve such high cutting performance.



#40 Carbon steel

CUTTING CONDITIONS

MACHINE TOOL	BBT40 (Vertical Machining Center)
TOOL HOLDER	(BIG) FULL CUT MILL BBT40-FCM50115-70
INSERT	ARG401104(ACZ350) 3 cutting edges
WORK MATERIAL	S50C(C50)
SPINDLE SPEED	1,270 (min ⁻¹)
CUTTING SPEED	200 (m/min.)
FEED RATE	0.15 (mm/tooth)
DEPTH OF CUT	1 (mm)
WIDTH OF CUT	30 (mm)

● RESULT
Combination of BIG-PLUS and FULLCUT MILL resulted in beautiful surface finish.

Surface roughness Rz	
BIG-PLUS (FULLCUT MILL)	2.53
Manufacturer A	3.75
Manufacturer B	4.32

BIG-PLUS APPLICATION EXAMPLES



BORING Applications

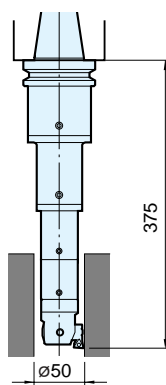

#50 Carbon steel	
CUTTING CONDITIONS	
MACHINE TOOL	BBT50 (Horizontal Machining Center) (BIG-PLUS) CK BORING SYSTEM
TOOL HOLDER	BBT50-CK7-210 BT50-CK7-210 +CK76-160+CK64-115 +CK44-45+EWN41-74CKB4
CUTTER	T1200A (Nose R0.4)
WORK MATERIAL	S50C(C50)
SPINDLE SPEED	1,146 (min ⁻¹)
CUTTING SPEED	125 (m/min.)
FEED RATE	92 (mm/min.) 0.08 (mm/rev.)
BORING DIAMETER	50 (mm)
CUTTING DEPTH	0.25 (mm/φ)

RESULT

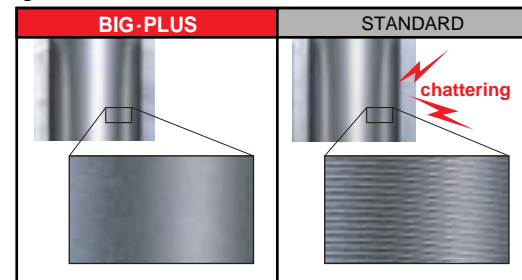

A standard holder caused chattering and left marks like scales. BIG-PLUS holder enabled cutting without problems.

Increased Rigidity

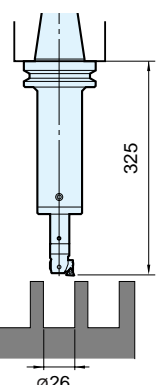

#50 Carbon steel	
CUTTING CONDITIONS	
MACHINE TOOL	BBT50 (Vertical Machining Center) (BIG-PLUS) CK BORING SYSTEM
TOOL HOLDER	BBT50-CK6-300 BT50-CK6-300 +CK62-80+EWN25-47CKB2
CUTTER	T1200A (Nose R0.2)
WORK MATERIAL	S50C(C50)
SPINDLE SPEED	2,200 (min ⁻¹)
CUTTING SPEED	180 (m/min.)
FEED RATE	154 (mm/min.) 0.07 (mm/rev.)
BORING DIAMETER	26 (mm)
CUTTING DEPTH	0.2 (mm/φ)

RESULT

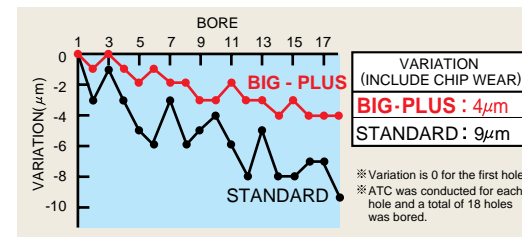

Improved repeatability of BIG-PLUS holder at ATC achieved stable dia. of boring.

Improved Accuracy

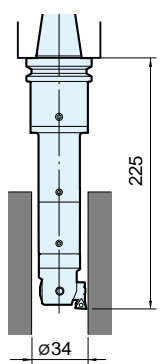

#40 Carbon steel	
CUTTING CONDITIONS	
MACHINE TOOL	BBT40 (Horizontal Machining Center) (BIG-PLUS) CK BORING SYSTEM
TOOL HOLDER	BBT40-CK6-135 BT40-CK6-135 +CK63-115+CK33-30 +EWN32-60CKB3
CUTTER	T1200A (Nose R0.2)
WORK MATERIAL	S50C(C50)
SPINDLE SPEED	1,686 (min ⁻¹)
CUTTING SPEED	180 (m/min.)
FEED RATE	118 (mm/min.) 0.07 (mm/rev.)
BORING DIAMETER	34 (mm)

RESULT

	Cutting depth(mm/φ)		
	0.1	0.2	0.3
BIG-PLUS	0.2mm/φ		
STANDARD	0.15mm/φ		

Wide performance range of BIG-PLUS holder enabled smooth cutting without chattering even for rough prepared holes.

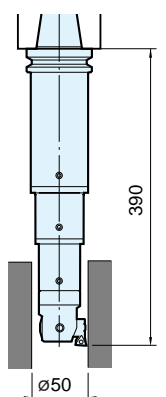

#50 Carbon steel	
CUTTING CONDITIONS	
MACHINE TOOL	BBT50 (Horizontal Machining Center) (BIG-PLUS) CK BORING SYSTEM
TOOL HOLDER	BBT50-CK6-300 BT50-CK6-300 +CK65-115+CK54-70 +EWN41-74CKB4
CUTTER	T1200A (Nose R0.2)
WORK MATERIAL	S50C(C50)
SPINDLE SPEED	900 (min ⁻¹)
CUTTING SPEED	140(m/min.)
FEED RATE	90 (mm/min.) 0.1 (mm/rev.)
BORING DIAMETER	50 (mm)

RESULT

	Cutting depth(mm/φ)		
	0.1	0.2	0.3
BIG-PLUS	0.3mm/φ		
STANDARD	0.15mm/φ		

Wide cutting performance of BIG-PLUS holder enabled smooth cutting without chattering even for roughly prepared holes.



FACE MILLING Applications

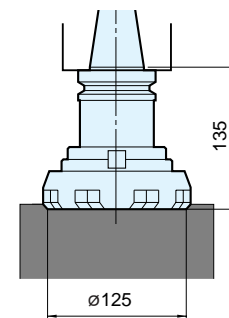

#40 Aluminum	
CUTTING CONDITIONS	
MACHINE TOOL	BBT40(Horizontal Machining Center) (BIG-PLUS) FACE MILL ARBOR TYPE A
TOOL HOLDER	BBT40-FMA38.1-60 BT40-FMA38.1-60
CUTTER	φ125(6 cutting edges)
WORK MATERIAL	A2017 Duralumin
SPINDLE SPEED	510(min ⁻¹)
CUTTING SPEED	200(m/min.)
FEED RATE	306(mm/min.) 0.1(mm/tooth)
BORING DIAMETER	125(mm)
CUTTING DEPTH	2.4(mm)

RESULT

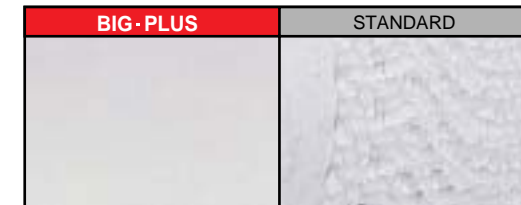

A standard holder caused chattering and left marks like scales. BIG-PLUS holder enabled cutting without problems.

Excellent surface finish

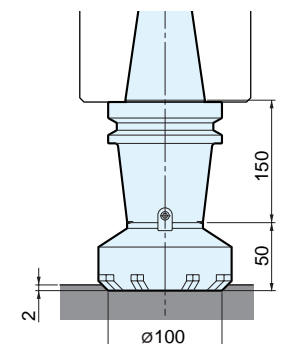

#50 Cast iron	
CUTTING CONDITIONS	
MACHINE TOOL	BBT50(Horizontal Machining Center) (BIG-PLUS) FACE MILL ARBOR TYPE A
TOOL HOLDER	BBT50-FMA31.75-150 BT50-FMA31.75-150
CUTTER	φ100 (5 cutting edges)
WORK MATERIAL	250
SPINDLE SPEED	477 (min ⁻¹)
CUTTING SPEED	150 (m/min.)
FEED RATE	954 (mm/min.) 0.4 (mm/tooth)
BORING DIAMETER	100 (mm)
CUTTING DEPTH	2 (mm)

RESULT

	BIG-PLUS	STANDARD
Ry max.(μm)	14.69	22.70

Surface roughness was improved.

Excellent surface finish

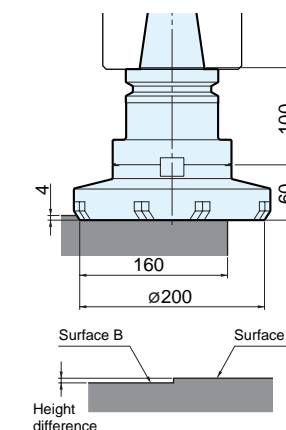

#50 Stainless steel	
CUTTING CONDITIONS	
MACHINE TOOL	BBT50 (Vertical Machining Center) (BIG-PLUS) FACE MILL ARBOR TYPE A
TOOL HOLDER	BBT50-FMA47.625-100 BT50-FMA47.625-100
CUTTER	φ200 (10 cutting edges)
WORK MATERIAL	SUS304 Stainless steel
SPINDLE SPEED	320 (min ⁻¹)
CUTTING SPEED	200(m/min.)
FEED RATE	1,280 (mm/min.) 0.4 (mm/tooth)
BORING DIAMETER	160 (mm)
CUTTING DEPTH	4 (mm)

RESULT

	Height difference on surfaces A and B
BIG-PLUS	None
STANDARD	In the order of 0.1mm

Rigidity increased.

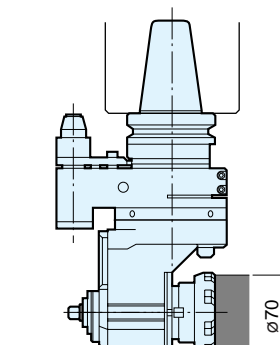

#50 Carbon steel	
CUTTING CONDITIONS	
MACHINE TOOL	BBT50(Vertical Machining Center) (BIG-PLUS) ANGLE HEAD
TOOL HOLDER	BBT50-AG90/AGH35-230 BT50-AG90/AGH35-230
CUTTER	φ80(4 cutting edges)
WORK MATERIAL	S55C(C55)
SPINDLE SPEED	600(min ⁻¹)
CUTTING SPEED	150(m/min.)
FEED RATE	370(mm/min.) 0.15(mm/tooth)
CUTTING DEPTH	70(mm)

RESULT

	Cutting depth		
	1.0	2.0	3.0
BIG-PLUS	2.5mm		
STANDARD	2.0mm		

Cutting efficiency is increased to 1.25 times greater than a standard holder. BIG-PLUS is applicable to Angle Heads.

Reduced machining time