

Suction Filters

Pi 1710

Nominal size up to 480

1. Features

Pumps incorporated in hydraulic systems must be protected from coarse contaminants which when not removed by any other filtering devices may gain access to tank.

MAHLE suction filters, series Pi 1710, stand out for their rugged construction and large filter surface area.

The filter surface is dimensioned to ensure long life at the proper corresponding flow rate.

The installation should be ahead of the pump in the tank for optimal protection.

The standard filter material is a 100 µm stainless steel wire mesh.

- Rugged construction
- Large filtering surface area

Worldwide distribution



2. Flow rates/pressure drop curve complete filter

■ 500 mm²/s
■ 190 mm²/s
■ 33 mm²/s

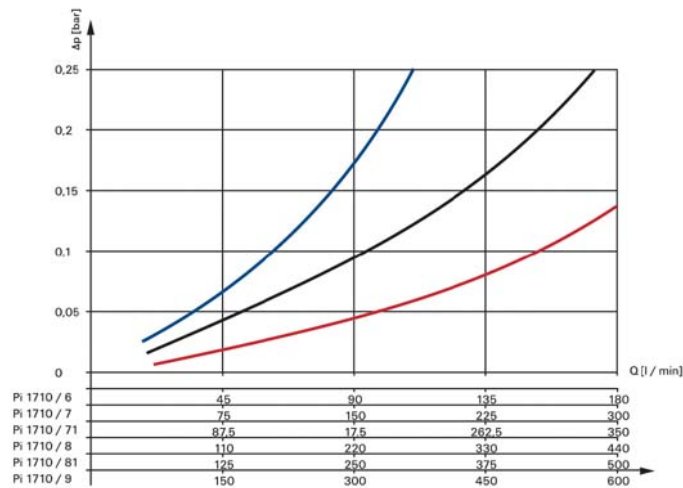
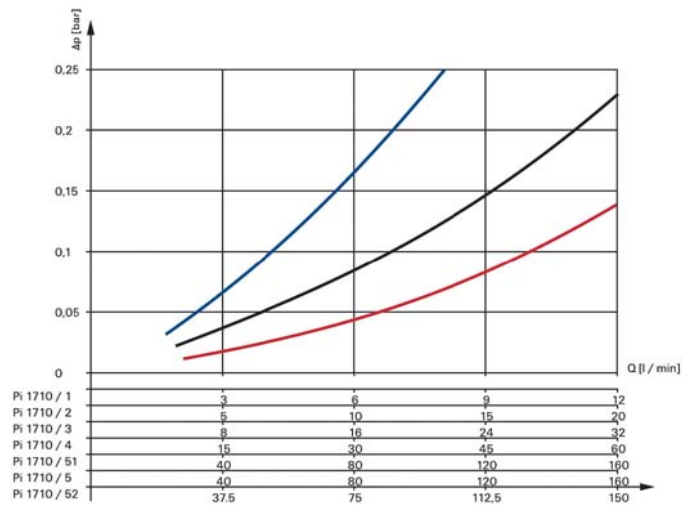

3. Order numbers

3.1 Housing design

Nominal size NG [l/min]	Order number	Type	Filter surface [cm ²]
10	77661598	Pi 1710/1	100
15	77661606	Pi 1710/2	115
30	77661614	Pi 1710/3	165
50	77661622	Pi 1710/4	420
60	77661697	Pi 1710/51	500
80	77661630	Pi 1710/5	670
120	77661705	Pi 1710/52	900
150	77661648	Pi 1710/6	1130
240	77661655	Pi 1710/7	1500
290	77661689	Pi 1710/71	1880
360	77661663	Pi 1710/8	2800
410	77661713	Pi 1710/81	3500
480	77661671	Pi 1710/9	3500

4. Specification

Flow capacity:	10 to 480 l/min at 33 mm ² /s viscosity and 0.1 bar Δ p
Temperature range:	-10 °C to +120 °C
Degree of filtration:	100 micron
Other ratings:	on request
Material of connecting port + end cap:	GD - Z 410, ab NG 150; PA 6 GF 30
Material of end cap:	galvanized steel
Material of inner tube:	galvanized steel
Material of wire mesh:	stainless steel 1.4301

We draw attention to the fact that all values indicated are average values which do not always occur in specific cases of application.

Our products are continually being further developed. Values, dimensions and weights can change as a result of this. Our specialized department will be pleased to offer you advice.

When using our filters on areas which are to be classified according to EU Directive 94/9 EG (ATEX 95), we recommend prior discussion with us.

The standard version can be used for liquids based on mineral oil (corresponding to the fluids in Group 2 of Directive 97/23 EC Article 9). Please consult with us if using other media.

Subject to technical alteration without prior notice.

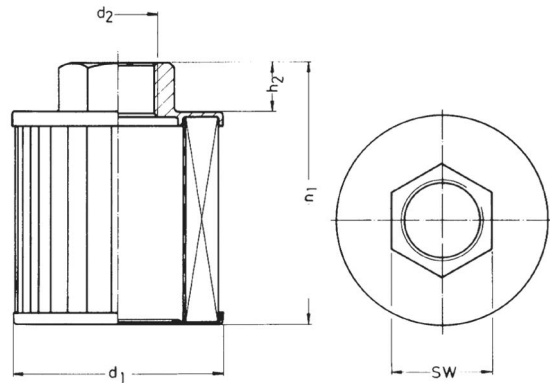

5. Dimensions

All dimensions except "d2" in mm.

Type	d ₁	d ₂	h ₁	h ₂	SW	Weight [kg]
Pi 1710/1	46	G ¼	60	18	22	0.10
Pi 1710/2	46	G 3/8	60	18	22	0.10
Pi 1710/3	61	G ½	53	13	27	0.14
Pi 1710/4	61	G ¾	89	16	36	0.20
Pi 1710/51	87	G 1	87	21	41	0.32
Pi 1710/5	87	G 1	108	21	41	0.35
Pi 1710/52	87	G 1	152	21	41	0.40
Pi 1710/6	98	G 1¼	122	21	46	1.00
Pi 1710/7	98	G 1½	159	28	50	1.00
Pi 1710/71	98	G 1½	189	28	50	1.05
Pi 1710/8	131	G 2	161	30	65	1.20
Pi 1710/81	131	G 2	191	30	65	1.40
Pi 1710/9	131	G 2 ½	198	37	80	1.50

6. Cleaning methods

a) Ultrasonic cleaning

Insert the contaminated suction filter element into an ultrasonic bath for approximately 3 minutes, then rinse in clean liquid. Afterwards, blow air into the filter from the clean side outward.

The cleaning effect is approximately 80-90 %.

b) Manual cleaning

1. Remove coarse external contamination in a separate cleaning tank using a brush and cleaning agent.
2. Place filter in unused cleaning liquid (approximately 20 minutes)
3. Wash filter with cleaning liquid from the inside to the outside. The cleaning effect is approximately 60-70 %.

Using either method be sure that no dirt is washed on the inside of the element.

MAHLE

Industrial Filtration

MAHLE Filtersysteme GmbH
Industriefiltration
Schleifbachweg 45
D-74613 Öhringen
Phone +49 (0) 7941/67-0
Fax +49 (0) 7941/67-23429
industriefiltration@mahle.com
www.mahle-industriefiltration.com
78357287.11/2006