

### Low Pressure Filter

Pi 270

Operating pressure 10 bar, Nominal size up to 315

#### 1. Features

##### Efficient filters for hydraulic systems

- Modular design principle
- Compact design
- Minimal pressure drop
- Optical/electrical/electronic contamination control
- Thread connection

##### Quality filters, easy to service

- Equipped with highly efficient Mic- or Sm-x filter elements
- $\beta$ -valued elements per ISO 16889
- High dirt holding capacity and differential pressure stability providing optimal element service life.

##### Worldwide distribution



## 2. Flow rate/pressure drop curve complete filter

190 mm<sup>2</sup>/s (25° E)  
33 mm<sup>2</sup>/s (4,5° E)

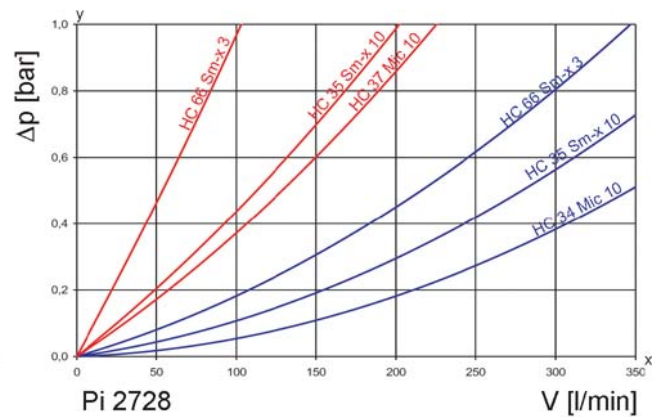
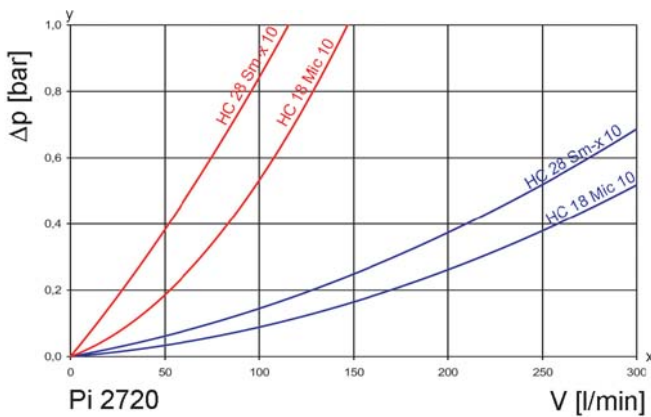

y = differential pressure  $\Delta p$  [bar]  
x = flow rate V [l/min]

## 3. Separation characteristics

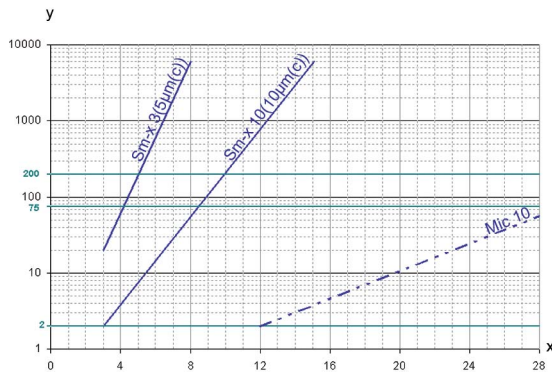

y = beta-ratio  
x = particle size [ $\mu\text{m}$ ]

determined by multipass test (ISO 16889)  
calibration according to ISO 11171 (NIST)

## 4. Quality assurance

MAHLE filter and filter elements are manufactured respectively, tested in accordance with following international standards:

Norm	Designation
DIN ISO 2941	Hydraulic fluid power filter elements; verification of collapse/burst resistance
DIN ISO 2942	Hydraulic fluid power filter elements; verification of fabrication integrity
DIN ISO 2943	Hydraulic fluid power filter elements; verification of material compatibility with fluids
DIN ISO 3723	Hydraulic fluid power filter elements; method for end load test
DIN ISO 3724	Hydraulic fluid power filter elements; verification of flow fatigue characteristics
ISO 3968	Hydraulic fluid power filters; evaluation of pressure drop versus flow characteristics
ISO 10771.1	Fatigue pressure testing of metal containing envelopes in hydraulic fluid applications
ISO 16889	Hydraulic fluid power filters; multipass method for evaluation filtration performance of a filter element

## 5. Order numbers for pressure- side installation

Example for ordering filters:

1. Housing design	2. 2x filter elements
V = 250 l/min, bypass, electrical differential pressure indicator Type: Pi 2720-058 Order number: 77694060	Mic 10 Type: HC 18 Order number: 77643331

5.1 Housing design								
Nominal size NG [l/min]	Order number	Type	① no options	② with bypass 3.5 bar	③ with bypass 3.5 bar and optical indicator	④ with bypass 3.5 bar and electrical indicator	⑤ with optical indicator	⑥ with electrical indicator
250	77694011	Pi 2720-060						
	77694029	Pi 2720-056						
	77694078	Pi 2720-057						
	77694060	Pi 2720-058						
	77694045	Pi 2720-068						
	77694037	Pi 2720-069						
315	77694128	Pi 2728-060						
	77694136	Pi 2728-056						
	77694185	Pi 2728-057						
	77694177	Pi 2728-058						
	77694151	Pi 2728-068						
	77694144	Pi 2728-069						

When filter with non bypass configuration is selected  $\Delta p$  of 5 bar may not be exceeded.

5.2 Spin-on cartridge					
Nominal size NG [l/min]	Order number	Type	Filter material	Collapse pressure [bar]	Filter surface [cm <sup>2</sup> ]
250	77643331	HC 18	Mic 10	5	7000
	77643398	HC 28	Sm-x 10		3400
315	77504194	HC 34	Mic 10	5	13500
	78714750	HC 66	Sm-x 3		7500
	77643844	HC 35	Sm-x 10		7500

## 6. Order number for suction-side installation

### 6.1 Housing design

Nominal size NG [l/min]	Order number	Type	① no options	② with bypass 0.25 bar	⑦ with bypass 0.25 bar + vacuum gauge	⑧ with bypass 0.25 bar + vacuum switch	⑨ with vacuum switch	⑩ with vacuum gauge
80	77694011	Pi 2720-060						
	77694094	Pi 2720-067						
	77694102	Pi 2720-062						
	77694110	Pi 2720-061						
	77694086	Pi 2720-065						
	77694052	Pi 2720-066						
125	77694128	Pi 2728-060						
	77694201	Pi 2728-067						
	77694219	Pi 2728-062						
	77694227	Pi 2728-061						
	77694193	Pi 2728-065						
	77694169	Pi 2728-066						

When filter with non bypass configuration is selected  $\Delta p$  of 5 bar may not be exceeded.

### 6.2 Spin-on cartridge

Nominal size NG [l/min]	Order number	Type	Filter material	Collapse pressure [bar]	Filter surface [cm <sup>2</sup> ]
80	77643331	HC 18	Mic 10	5	7000
125	77504194	HC 34	Mic 10		13500

## 7. Symbols

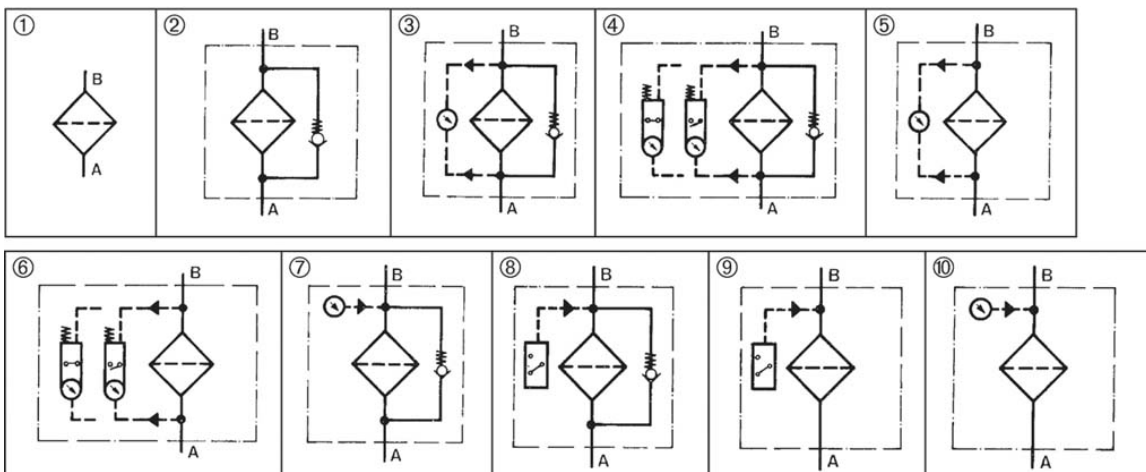

## 8. Specifications

Design:	line mounting filter
Operating pressure:	10 bar
Test pressure:	13 bar
Temperature range:	-10 °C to +120 °C (other temperature ranges on request)
Bypass opening pressure:	
Pressure side:	$\Delta p$ 3.5 bar $\pm$ 10 %
Suction side:	$\Delta p$ 0.25 bar $\pm$ 10 %
Filter head material:	GAL
Spin-on cartridge material:	St
Sealing material:	NBR/AL
Activating optical/electrical differential pressure indicator:	$\Delta p$ 2.2 bar $\pm$ 10 %
Indicating range vacuum gauge:	-1 bar to +1.5 bar
Pressure setting vacuum switch:	200 mbar
Type of protection (suction side):	IP 54
Electrical data of differential pressure indicator:	
Maximum voltage:	250 V AC/200 V DC
Maximum current on contact:	1 A
Inrush current:	70 W
Type of protection:	IP 65 when inserted and secured
Contact:	bistable
Cable connection:	M 20 x 1.5

The switching function can be changed by turning the electric upper part by 180 ° (normally closed contact or normally open contact). The state on delivery is a normally closed contact. The use of quenching circuits must be checked in the case of inductivity in the DC current circuit. The contamination indicator data sheet contains further information and additional contamination indicator versions.

Mic and Sm-x spin-on cartridges are opposed to mineral oil.

Please consult with us if using other media.

We draw attention to the fact that all values indicated are average values which do not always occur in specific cases of application. Our products are continually being further developed. Values, dimensions and weights can change as a result of this. Our specialized department will be pleased to offer you advice.

When using our filters in areas which are to be classified according to EU Directive 94/9 EC (ATEX 95), we recommend prior discussion with us.

Subject to technical alteration without prior notice.

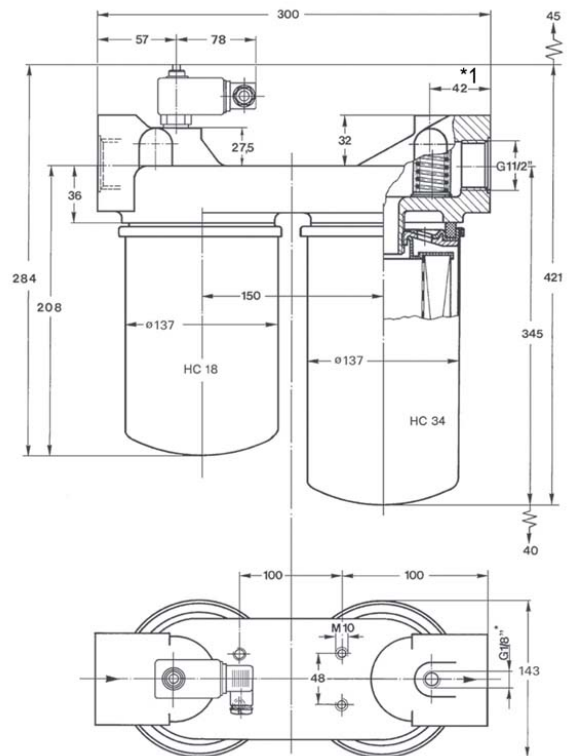

\*1 only existing at suction side design

## 9. Installation, operating and maintenance instructions

### 9.1 Filter installation

When installing the filter make sure that sufficient space is available to remove spin-on cartridge. Filter should be installed with the spin-on cartridge pointing downwards. The contamination indicator must be visible.

### 9.2 Connecting the electrical contamination indicator

The electrical indicator is connected via a 2-pole appliance plug according to DIN EN 175301-803 with poles marked 1 and 2.

The electrical section can be inverted to change from normally open position to normally closed position or vice versa.

### 9.3 When must the filter element be replaced?

- Filters equipped with optical and electrical contamination indicator:  
During cold starts, the indicator may give a warning signal. Depress the red button of the visual indicator once again only after operating temperature has been reached. If the red button immediately pops out again and/or the electrical signal has not switched off after reaching operating temperature, the filter element must be replaced after the end of the shift.
- Filters without contamination indicator:  
The filter element should be replaced after the trial run or flushing of the system. Afterwards follow instructions of the manufacturer.
- Please always ensure that you have Original MAHLE replacement elements in stock: disposable elements (Sm-x) cannot be cleaned.

### 9.4 Spin-on cartridge replacement

- Stop system and relieve filter from pressure.
- Unscrew the spin-on cartridge by using a filter wrench by turning counter-clockwise.
- Make sure that the order number on the spin-on cartridge corresponds with the order number of the plate.
- Oil the seal of the spin-on cartridge.
- Spin-on cartridge must be installed according to the printed instructions.

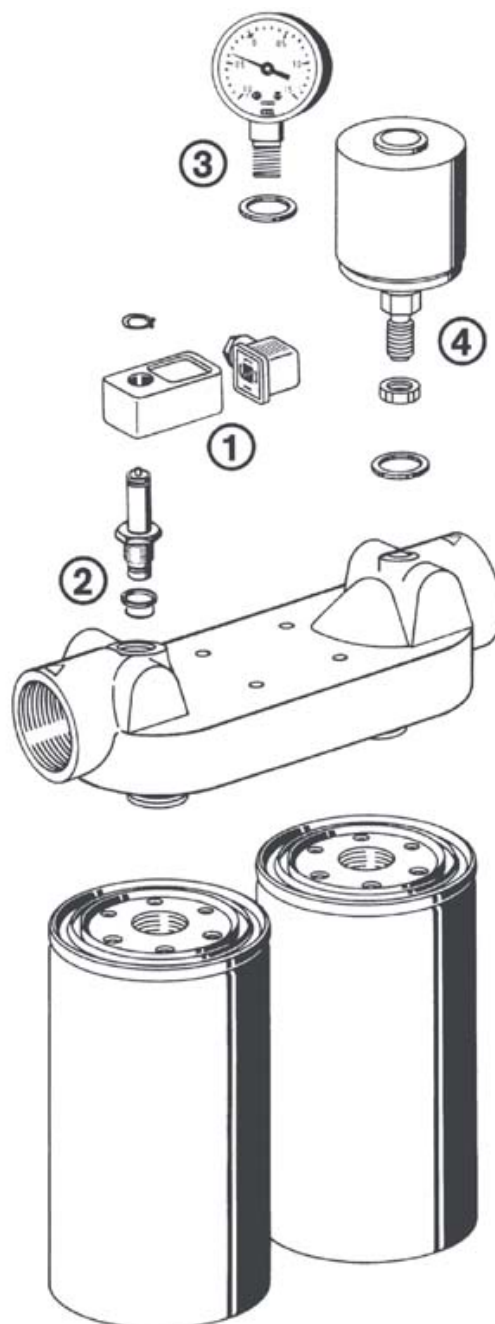

## 10. Spare parts list

Order numbers for spare parts		
Position	Type	Order number
①	Contamination indicator	
	Optical PiS 3098/2.2	77669971
	Electrical PiS 3097/2.2	77669948
	Electrical upper section only	77536550
②	Seal kit for contamination indicator	
	NBR	77760309
③	Vacuum gauge	77548027
④	Vacuum switch	
	PiS 3070/200 mbar	77669724

MAHLE Filtersysteme GmbH  
 Industriefiltration  
 Schleifbachweg 45  
 D-74613 Öhringen  
 Phone +49 (0) 7941/67-0  
 Fax +49 (0) 7941/67-23429  
 industriefiltration@mahle.com  
 www.mahle-industriefiltration.com  
 78356677.11/2006