

### Line filter

### Pi 1907

Operating pressure 16 bar, NG 400 up to 6000

#### 1. Features

##### Efficient filters for modern hydraulic systems

- Compact design principle
- Minimal pressure loss
- Optical/electrical/electronic contamination control
- Flange ports

##### Quality filters, easy to service

- Highly efficient Sm-x filter elements
- $\beta$ -valued elements per ISO 4572
- Large dirt holding capacity and high differential pressure stability providing optimal service life
- 100 % bubble-point tested elements

##### Worldwide distribution



## 2. Separation characteristics

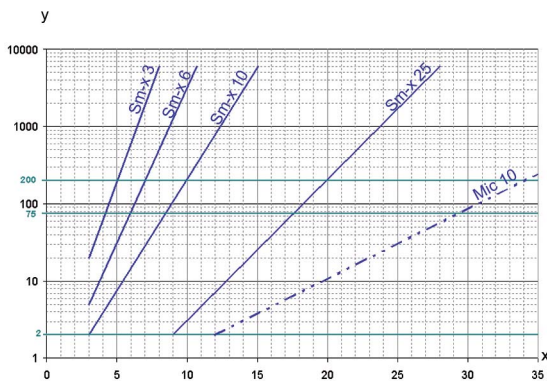

y = beta-ratio

x = particle size [ $\mu\text{m}$ ]

determined by multipass test (ISO 16889)

calibration according to ISO 11171 (NIST)

## 3. Filter performance data

measured according to ISO 16889 (multipass test)

Sm-x-elements with  $\Delta p$  10 bar

Sm-x 3  $\beta_{3(C)} \geq 75$

Sm-x 6  $\beta_{6(C)} \geq 75$

Sm-x 10  $\beta_{10(C)} \geq 75$

Sm-x 25  $\beta_{25(C)} \geq 75$

at 5 bar differential pressure

## 4. Quality assurance

MAHLE filter and filter elements are manufactured respectively; tested in accordance with the following international standards:

Norm	Designation
DIN ISO 2941	Hydraulic fluid power filter elements; verification of collapse/burst resistance
DIN ISO 2942	Hydraulic fluid power filter elements; verification of fabrication integrity
DIN ISO 2943	Hydraulic fluid power filter elements; verification of material compatibility with fluids
DIN ISO 3723	Hydraulic fluid power filter elements; method for end load test
DIN ISO 3724	Hydraulic fluid power filter elements; verification of flow fatigue characteristics
ISO 3968	Hydraulic fluid power-filters-evaluation of pressure drop versus flow characteristics
ISO 10771.1	Fatigue pressure testing of metal containing envelopes in hydraulic fluid applications
ISO 16889	Hydraulic fluid power filters; multipass method for evaluation filtration performance of a filter element

## 5. Symbols

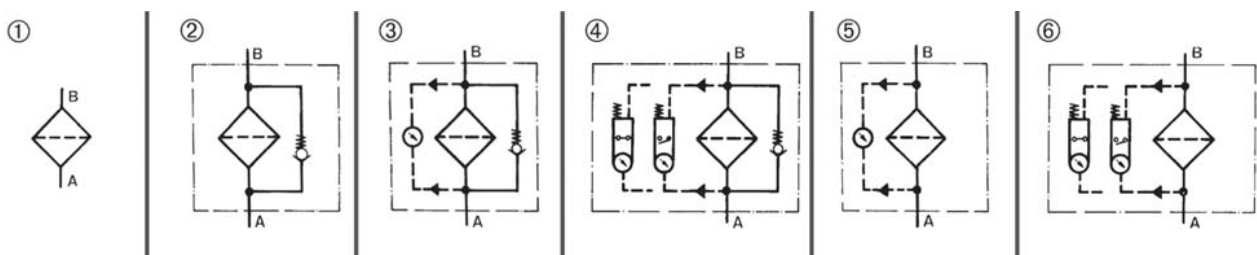

① without options

② with bypass valve

③ with bypass valve, optical indicator

④ with bypass valve, electrical indicator

⑤ with optical indicator

⑥ with electrical indicator

## 6. Types (Example for ordering filters)

Pi 1907	3	16	150	V	E	Mg	Abh	852888 Sm-x 10
1	2	3	4	5	6	7	8	9

1 Filter type

2 Number of elements

(up to DN 125, 1 St., DIN 150 and 200 3 ea.)

3 Operating pressure

4 Connection size

5 Bypass valve

6 Contamination indicator

E = electrical, M = optical

7 Magnets

(available for flange size DN 100 up to DN 200)

8 Cover lifting device

(available for flange size DN 150, DN 200)

9 Filter element

## 7. Specifications

Design:

line mounting filter

Fitting position:

preferable upright

Operating pressure:

16 bar (NG 150 and 200 also possible with operating pressure 10 bar)

Connections:

NG	400	630	800	1250	1800	3500	6000
DN	50	65	80	100	125	150	200

Flange connections up to DN 200/ PN 16: DIN 2633

Flange connections DN 150 and DN 200/ PN 10: DIN 2632/DIN 2633

Temperature range:

- 10 °C to + 100 °C

(other temperature ranges on request)

Filter housing material:

steel welded construction

Material of seals:

NBR (other material on request)

Bypass opening pressure:

$\Delta p$  3.5 bar  $\pm$  10 %

Activating pressure of optical/  
electrical contamination indicator:

$\Delta p$  2.2 bar  $\pm$  10 %

Electrical data of

contamination indicator:

Maximum voltage:

230 V  $\sim$ /=

Maximum current on contact:

2.5 A

Maximum current load:

60 VA/40 W

Inrush current:

70 VA

Type of protection:

IP 65 when inserted and secured

Contact type:

bistable

Cable connection:

PG 11  $\varnothing$  6-10

Filter compatible with standard mineral oils.

Please consult us in case of using other media.

The electrical indicator function can be changed from the normally open position to the normally closed position or vice versa by inverting the electrical section. Inductivity in the direct current may require the use of a signal eraser.

For further information and executions please see our leaflet contamination indicators.

## 8. Commissioning

- Prior to commissioning the filter open the venting screw and wait until liquid emerges. Then tighten the venting screw.
- After that all sealing points must be optically inspected for leaks.
- If the contamination indicator gives a signal when the operating temperature has been reached, the filter element must be replaced after the end of the shift.
- For element replacement stop system and relieve filter from pressure. empty filter over drain plug, remove hex nuts, remove container top, remove hex nut, remove valve plate, remove nut, remove filter element.
- Clean filter housing using a suitable medium
- Clean contaminated filter elements or replace by new MAHLE filters (only Drg-elements are cleanable)
- Inspect all sealing points and seals and replace by new if required.
- Assembly is performed in reverse order
- Following commissioning inspect all sealing points for leaks.

## 9. Filter elements

Filter-material	Degree of filtration [µm]	NG 400/ DN 50	NG 630/ DN 80	NG 800/ DN 80	NG 1250/ DN 100	NG 1800/ DN 125	NG 3500/ DN 150	NG 6000/ DN 200
Sm-x Δ p 10 bar		(9090 cm <sup>2</sup> )	(14750 <sup>2</sup> )	(14750 cm <sup>2</sup> )	(21850 cm <sup>2</sup> )	(31750 cm <sup>2</sup> )	(65550 cm <sup>2</sup> )	(95250 cm <sup>2</sup> )
	3	Pi 21040 RN	Pi 21063 RN	Pi 21063 RN	852888 Sm-x 3	852884 Sm-x 3	852888 Sm-x 3	852884 Sm-x 3
	6	Pi 22040 RN	Pi 22063 RN	Pi 22063 RN	852888 Sm-x 6	852884 Sm-x 6	852888 Sm-x 6	852884 Sm-x 6
	10	Pi 23040 RN	Pi 23063 RN	Pi 23063 RN	852888 Sm-x 10	852884 Sm-x 10	852888 Sm-x 10	852884 Sm-x 10
	25	Pi 25040 RN	Pi 25063 RN	Pi 25063 RN	852888 Sm-x 25	852884 Sm-x 25	852888 Sm-x 25	852884 Sm-x 25
Mic Δ p 10 bar	10	(9450 cm <sup>2</sup> )	(15550 cm <sup>2</sup> )	(15550 cm <sup>2</sup> )	(21850 cm <sup>2</sup> )	(31750 cm <sup>2</sup> )	(65550 cm <sup>2</sup> )	(95250 cm <sup>2</sup> )
		Pi 13040 RN	Pi 13063 RN	Pi 13063 RN	852888 Mic 10	852884 Mic 10	852888 Mic 10	852884 Mic 10
Drg Δ p 10 bar		(6370 cm <sup>2</sup> )	(10320 cm <sup>2</sup> )	(10320 cm <sup>2</sup> )	(16500 cm <sup>2</sup> )	(23700 cm <sup>2</sup> )	(49500 cm <sup>2</sup> )	(71100 cm <sup>2</sup> )
	25	Pi 35040 RN	Pi 35063 RN	Pi 35063 RN	852888 Drg 25	852884 Drg 25	852888 Drg 25	852884 Drg 25
	40	Pi 36040 RN	Pi 36063 RN	Pi 36063 RN	852888 Drg 40	852884 Drg 40	852888 Drg 40	852884 Drg 40
	60	Pi 37040 RN	Pi 37063 RN	Pi 37063 RN	852888 Drg 60	852884 Drg 60	852888 Drg 60	852884 Drg 60
	100	Pi 38040 RN	Pi 38063 RN	Pi 38063 RN	852888 Drg 100	852884 Drg 100	852888 Drg 100	852884 Drg 100

( ) Filter surface area

## 10. Dimensions

All dimensions in mm.

Nominal size NG [l/min]	Connection size DN	Operating pressure PN [bar]	A	B	C	D	E	G	H	J	K
400	50	16	285	169	890	250	380	G ½	110	300	200
630	65		285	169	890	250	380	G ½	110	300	350
800	80		285	169	890	250	380	G ½	110	300	350
1250	100		340	220	935	365	450	G ½	200	380	450
1800	125		405	273	1200	435	500	G 1	235	450	450
3500	150		580	407	1330	600	690	G 1	300	440	450
6000	200	715	508	1465	550	740	G 1	270	500	450	
3500	150	10	565	407	1330	600	690	G 1	300	440	450
6000	200		670	508	1465	550	740	G 1	270	500	450

## 10. Dimensions

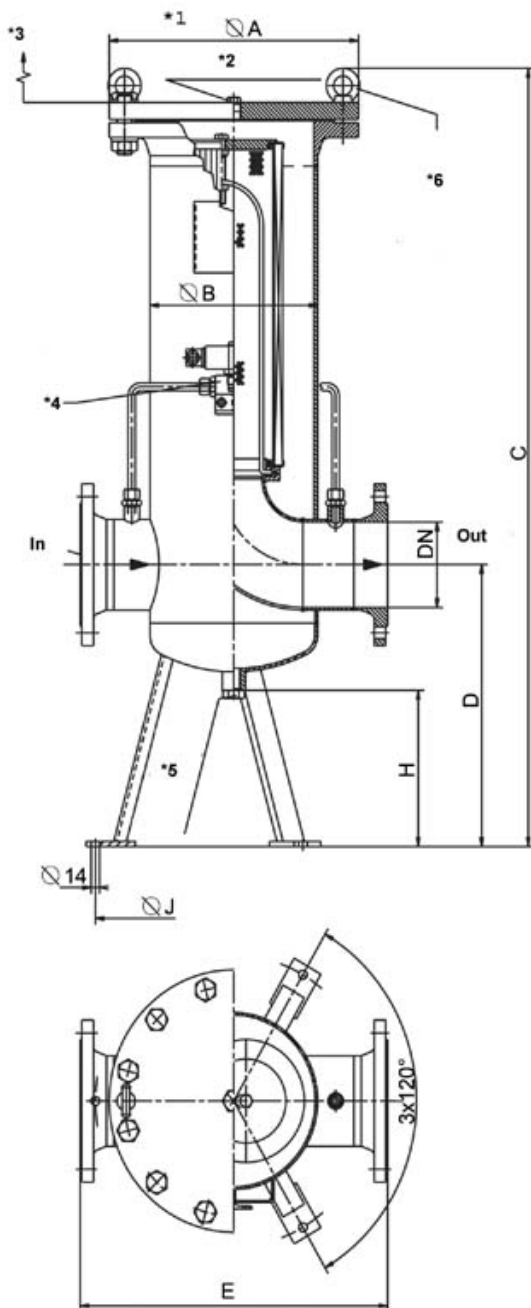

- \*1 illustration shows execution up to flange size DN 125
- \*2 vent screw
- \*3 "K" height required for element removal
- \*4 contamination indicator opt./el.
- \*5 drain plug "G"
- \*6 Lifting eye; available for executions starting with size DN 100

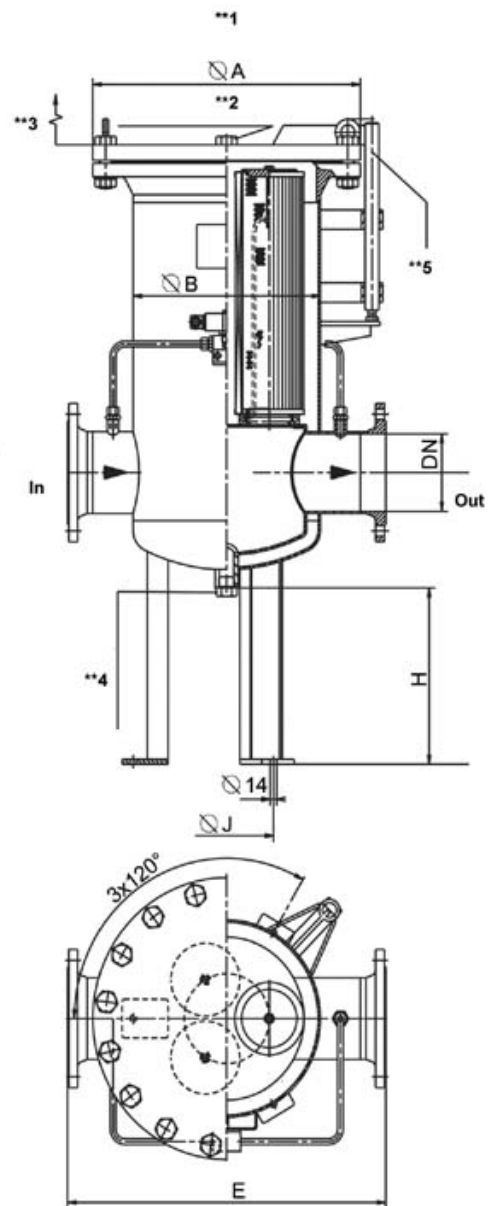

- \*\*1 illustration shows execution up to flange size DN 125
- \*\*2 vent screw
- \*\*3 "K" height required for element removal
- \*\*4 drain plug "G"
- \*\*5 cover lifting device

Subject to technical alteration without prior notice!

# MAHLE

*Industrial Filtration*

MAHLE Filtersysteme GmbH  
Industriefiltration  
Schleifbachweg 45  
D-74613 Öhringen  
Phone +49 (0) 7941/67-0  
Fax +49 (0) 7941/67-23429  
industriefiltration@mahle.com  
www.mahle-industriefiltration.com  
79322728.11/2006