

Mobile Filter Units

Pi 8100

Flow rates 27 and 55 l/min

1. Features

Efficient filters for modern hydraulic systems

- Mobile bypass filtration for hydraulic and lubricating systems
- System and container filling
- Pumping out of old oil
- Transfer pumping of container contents
- Reduces dirt loading of system filters on start-up and following repairs
- Achievement of specified cleanliness classes using MAHLE Sm-x filter elements
- Excellent contamination absorption performance using MAHLE Sm-N 2 filter elements

Quality filters, easy to service

- MAHLE low pressure filter Pi 150 housing with quick-release cover for fast element replacement
- Oil collection tank/automatic bleeding
- Automatic pump cut-off
- Low operating noise
- Robust feed pump with helical gearing and integrated bypass valve
- Suitable for mineral oils, HFC and biodegradable oils
- Good suction performance, also suitable for high viscosity products

Worldwide distribution



2. Flow rate/pressure drop curve complete filter

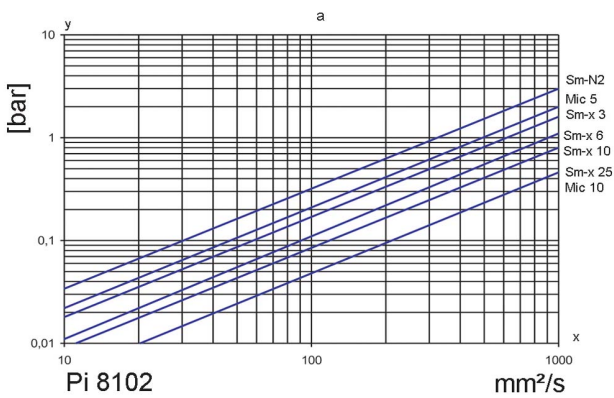

a = differential pressure-viscosity curve Pi 8102
 flow rate = 27 l/min
 y = differential pressure [bar]
 x = viscosity [mm²/s]

Illustration shows initial Δp of complete filter (housing incl. element) of the mobile filter units.

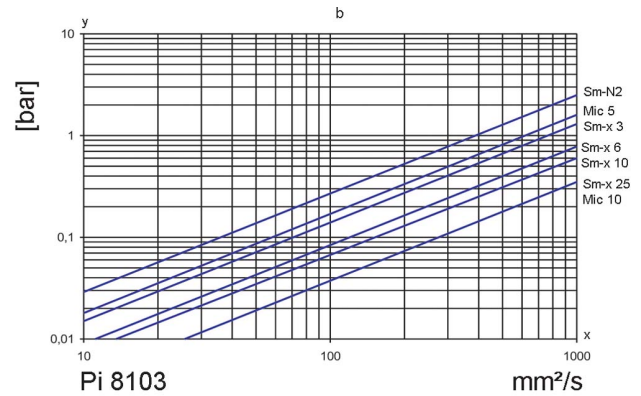

b = differential pressure-viscosity curve Pi 8103
 flow rate = 55 l/min
 y = differential pressure [bar]
 x = viscosity [mm²/s]

Recommended initial Δp :
 max. 0.5 bar at bypass filtration
 max. 0.8 bar for filling or transfer by pump

3. Separation characteristics

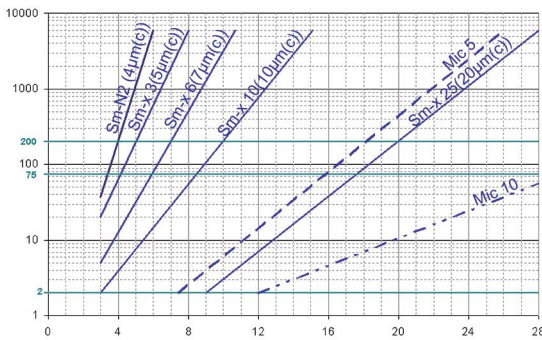

y = beta-ratio
 x = particle size [µm]

determined by multipass test (ISO 16889)
 calibration according to ISO 11171 (NIST)

4. Filter performance data

tested according to ISO 16889 (multipass test)

Sm-N	2	$\beta_{4(C)} \geq 200$
Sm-x	3	$\beta_{5(C)} \geq 200$
Sm-x	6	$\beta_{7(C)} \geq 200$
Sm-x	10	$\beta_{10(C)} \geq 200$
Sm-x	25	$\beta_{20(C)} \geq 200$

up to 10 bar differential pressure

The filter element Sm-N 2 has a very high dirt load capacity and is very suitable for bypass filtration.

5. Quality assurance

MAHLE filter and filter elements are manufactured respectively, tested in accordance with the following international standards:

Norm	Designation
DIN ISO 2941	Hydraulic fluid power filter elements; verification of collapse/burst resistance
DIN ISO 2942	Hydraulic fluid power filter elements; verification of fabrication integrity
DIN ISO 2943	Hydraulic fluid power filter elements; verification of material compatibility with fluids
DIN ISO 2923	Hydraulic fluid power filter elements; method for end load test
DIN ISO 2924	Hydraulic fluid power filter elements; verification of flow fatigue characteristics
ISO 3968	Hydraulic fluid power-filters-evaluation of pressure drop versus flow characteristics
ISO 10771.1	Fatigue pressure testing of metal containing envelopes in hydraulic fluid applications
ISO 16889	Hydraulic fluid power filters-multipass method for evaluation filtration performance of a filter element

6. Wiring diagramm

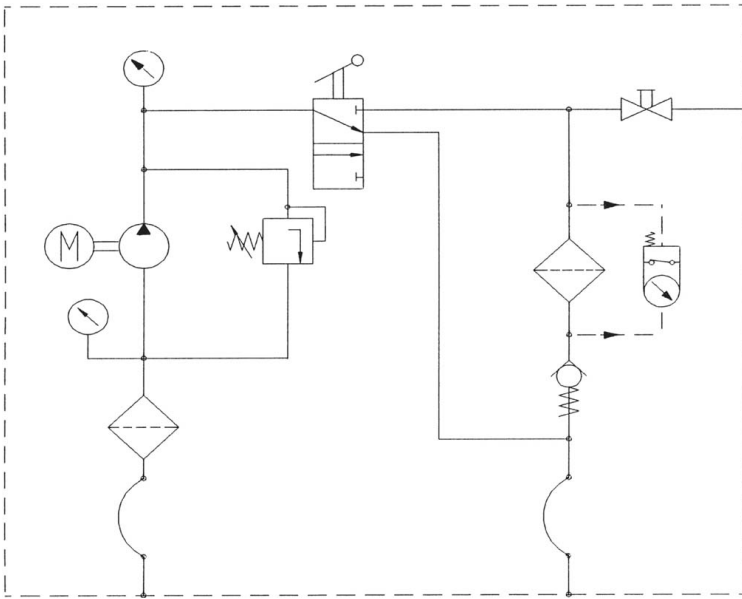

7. Order numbers

Example for ordering filters:

1. Filter Unit	2. Replacement element to 1
55 l/min with filter element Sm-N 2: Type: Pi 8103-069/852 761 Sm-N 2	Sm-N 2 Type: Pi 852 761 Sm-N 2 Order number: 78375867

7.1 Housing design*

Flow rate [l/min]	Type	Design
27	Pi 8102-069	with optical-electrical contamination indicator and pump cut off
55	Pi 8103-069	

* other designs available upon request.

7.2 Filterelemente*

Flow rate [l/min]	Order number	Type	Filter material	Collapse pressure [bar]	Filter Surface [cm ²]
27	77774458	852 760 Mic 5	Mic 5	5	23800
	77774441	852 760 Mic 10	Mic 10		23800
	77955859	852 760 Sm-N 2	Sm-N 2	10	16000
	77774433	852 760 Sm-x 3	Sm-x 3		14500
	78299042	852 760 Sm-x 6	Sm-x 6		14500
	77774425	852 760 Sm-x 10	Sm-x 10		14500
	77806565	852 760 Sm-x 25	Sm-x 25		14500
55	77774417	852 761 Mic 5	Mic 5	5	47600
	77774409	852 761 Mic 10	Mic 10		47600
	78375867	852 761 Sm-N 2	Sm-N 2	10	32000
	77774391	852 761 Sm-x 3	Sm-x 3		29000
	78225898	852 761 Sm-x 6	Sm-x 6		29000
	77774383	852 761 Sm-x 10	Sm-x 10		29000
	77806573	852 761 Sm-x 25	Sm-x 25		29000

* further elements available upon request.

8. Specifications

Filtration unit type	Pi 8102-069	Pi 8103-069
Delivery flow	27 l/min	55 l/min
Motor output	0.75 KW/1450 1/min	1.5 KW/1450 1/min
Power supply	230/400 V/50 Hz	230/400 V/50 Hz
Connection cable	7 m with EEC connector	7 m with EEC connector 5 bar
Pressure limiting valve	5 bar	
Pumpe, type	WP gear pump with outward-facing helical gear shafts	WP gear pump with outward-facing helical gear shafts
Pump protection filter	Cleanable 150 µm wire mesh suction filter	Cleanable 150 µm wire mesh suction filter
Minimum suction pressure	0.6 bar	0.6 bar
Maximum suction pressure	1.4 bar	1.4 bar
Pump viscosity range	7.5 - 2500 mm ² /s	7.5 - 2500 mm ² /s
Pump temperature range	-20°C to +120 °C	-20°C to +120 °C
MAHLE low pressure filter	Pi 1535/10-069	Pi 1560/10-069
Nominal pressure	10 bar	10 bar
Filter element	see options table	see options table
Filter area loading	0.0011-0.0019 l/min/cm ²	0.0012-0.0019 l/min/cm ²
Filter monitor	opt./electr. differential pressure indicator and automatic pump cut-off	opt./electr. differential pressure indicator and automatic pump cut-off
Δp reading threshold pressure	2.2 bar	2.2 bar
Unit monitor	Vacuum pressure gauge at the pump and pressure gauge suction points	Vacuum pressure gauge at the pump and pressure gauge suction points
Filtration unit/ filter element operating range	see differential/ viscosity curves	see differential pressure/ viscosity curves
Pipes	Screw fittings and pipes are zinc plated and chromated	Screw fittings and pipes are zinc plated and chromated
2.5 m flexible suction pipe, transparent, with suction pipe	DN 25	DN 38
2.5 m, flexible delivery pipe, with pipe lance	DN 19	DN 25
Noise level	< 72 db (A)	< 72 db (A)
Seals	FPM (Viton)*	FPM (Viton)*
Weight	approx. 80 kg	approx. 108 kg

* other seals can be supplied on request

We draw attention to the fact that all values indicated are average values which do not always occur in specific cases of application. Our products are continually being further developed. Values, dimensions and weights can change as a result of this. Our specialized department will be pleased to offer you advice.

When using our filters in areas which are to be classified according to EU Directive 94/9 EC /ATEX 95), we recommend prior discussion with us. The standard version can be used for liquids based on mineral oil (corresponding to the fluids in Group 2 of Directive 97/23 EC Article 9). Please consult with us if using other media.

Subject to technical alteration without prior notice.

8. Specifications

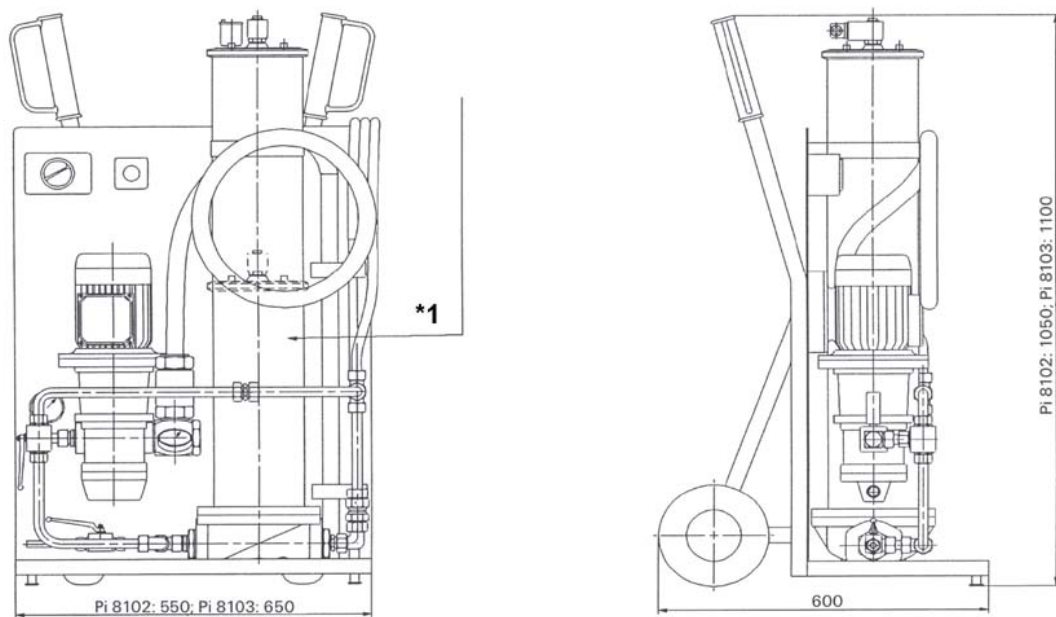

*1

low pressure filter
Pi 8102 (dashed): Pi 1535
Pi 8103: Pi 1560

MAHLE

Industrial Filtration

MAHLE Filtersysteme GmbH
Industriefiltration
Schleifbachweg 45
D-74613 Öhringen
Phone +49 (0) 7941/67-0
Fax +49 (0) 7941/67-23429
industriefiltration@mahle.com
www.mahle-industriefiltration.com
79781899.11/2006