

## Greiferfingerrohlinge

### Anwendungsbeispiele Fingerrohlinge

① KTG



② DPG

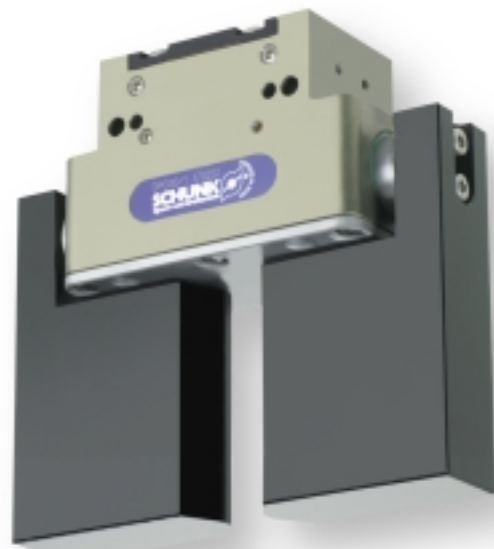



## Vorteile

- passende Fingerrohlinge für gängige Greifertypen
- einfach zu montieren
- hohe Austauschgenauigkeit
- Spannkontur kann schnell und einfach eingearbeitet werden
- schnelle Verfügbarkeit
- Aluminium-Fingerrohlinge aus hochfester Aluminium-Legierung
- Stahl-Fingerrohlinge aus härtbarem Einsatzstahl

# Fingerrohlinge

## Fingerrohlinge für MPG-Baureihe Type ABR



2-Finger-Parallelgreifer  
Type MPG

Type	Material	Ident-Nr.
ABR 20	Aluminium	340 210

Maße ABR 20

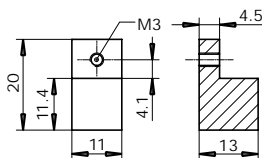

Type	Material	Ident-Nr.
ABR 25	Aluminium	340 211

Maße ABR 25

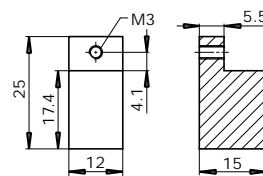

Type	Material	Ident-Nr.
ABR 32	Aluminium	340 212

Maße ABR 32

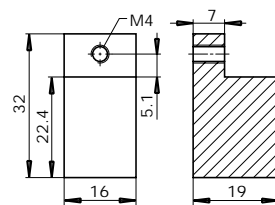

Type	Material	Ident-Nr.
ABR 40	Aluminium	340 213

Maße ABR 40

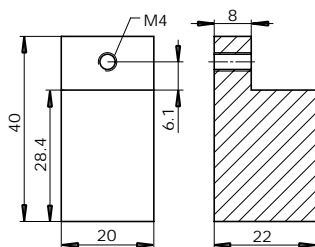

Type	Material	Ident-Nr.
ABR 50	Aluminium	340 214

Maße ABR 50

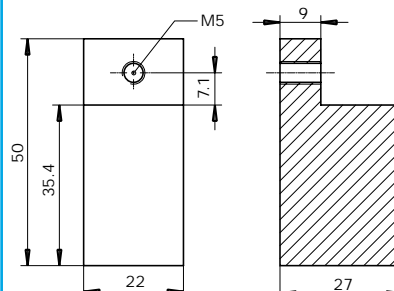

Type	Material	Ident-Nr.
ABR 64	Aluminium	340 215

Maße ABR 64

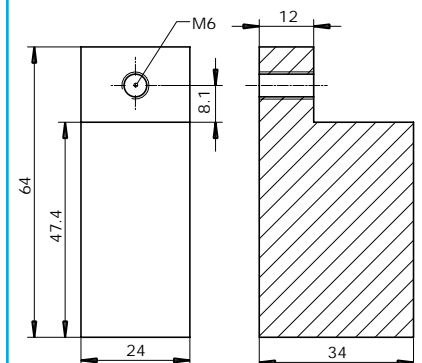

1 Satz = 2 Stück

# Fingerrohlinge

Fingerrohlinge für PGN-plus-Baureihe  
Type ABR plus und SBR plus  
(inklusive Schrauben)



2-Finger-Parallelgreifer  
Type PGN-plus  
mit Sonderfingern

## PGN-plus 64

Type	Material	Ident-Nr.
ABR 64 plus	Aluminium	300 010
SBR 64 plus	Stahl	300 020

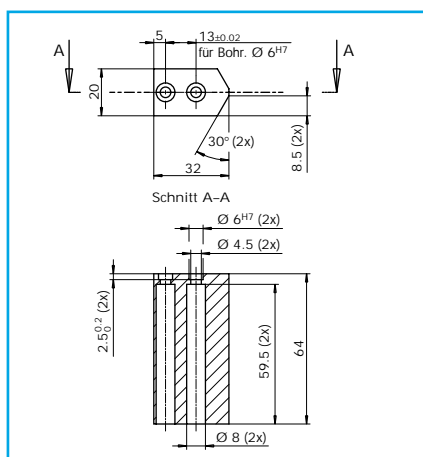

## PGN-plus 80

Type	Material	Ident-Nr.
ABR 80 plus	Aluminium	300 011
SBR 80 plus	Stahl	300 021

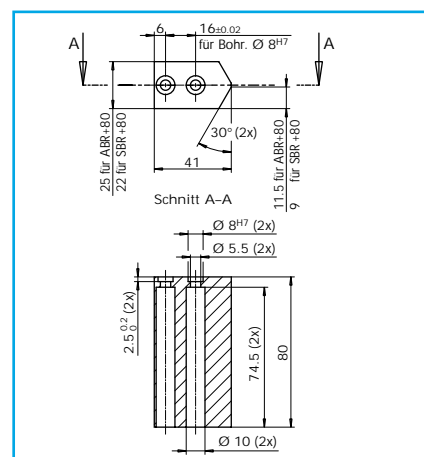

## PGN-plus 100

Type	Material	Ident-Nr.
ABR 100 plus	Aluminium	300 012
SBR 100 plus	Stahl	300 022

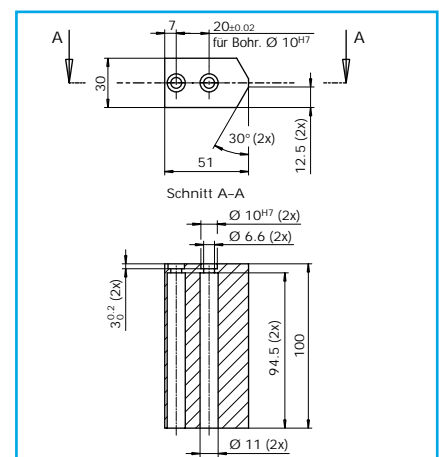

## PGN-plus 125

Type	Material	Ident-Nr.
ABR 125 plus	Aluminium	300 013
SBR 125 plus	Stahl	300 023

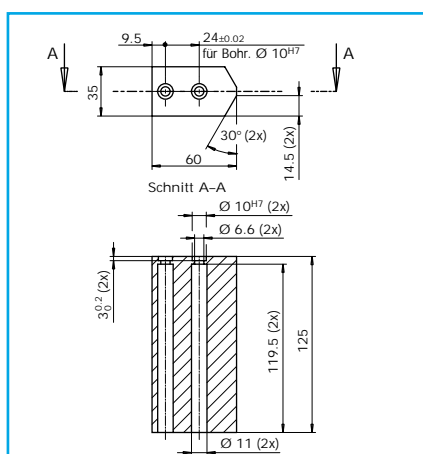

## PGN-plus 160

Type	Material	Ident-Nr.
ABR 160 plus	Aluminium	300 014
SBR 160 plus	Stahl	300 024

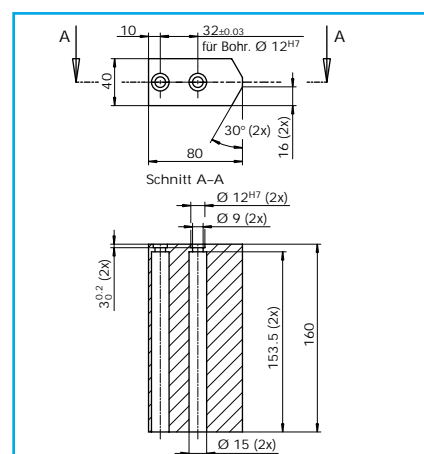

### Zubehör



#### Sonderlösungen

Für Ihre besonderen Anforderungen liefern wir Ihnen gerne und schnell kostengünstig Sonderlösungen, Sonderfinger, Anbauplatten und Komplettseinheiten.

Ident-Nr. für je 1 Stück

ABR

ABR+/SBR+

ABR/SBR

ZBH

AAB

RB

ASB

SBR

Quentes

HM/HKI

# Fingerrohlinge

Fingerrohlinge für PGN und PZN (HGN und HZN)  
Type ABR und SBR  
(inklusive Schrauben)

2-Finger-Parallelgreifer  
Type PGN mit Sonderfingern  
3-Finger-Zentrischgreifer  
Type PGN mit Sonderfingern



## PGN / PZN 50

Type	Material	Ident-Nr.
ABR 50	Aluminium	300 714
SBR 50	Stahl	300 715

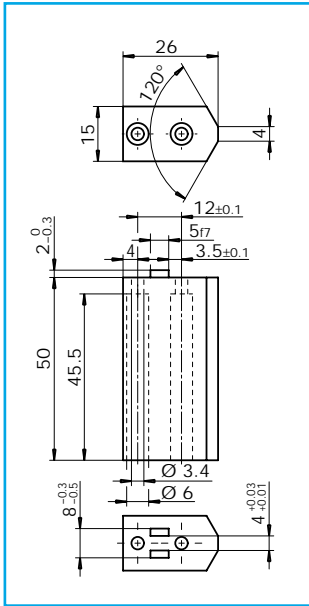

## PGN / PZN 64

Type	Material	Ident-Nr.
ABR 64	Aluminium	300 725
SBR 64	Stahl	300 734

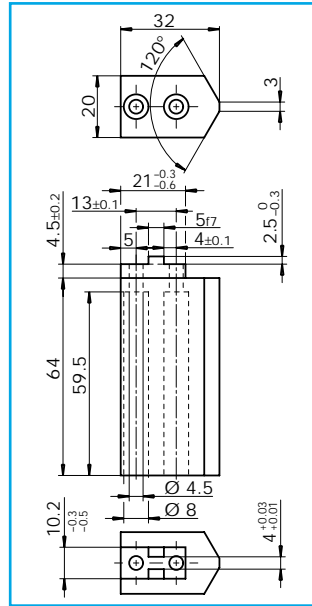

## PGN / PZN 80

Type	Material	Ident-Nr.
ABR 80	Aluminium	300 726
SBR 80	Stahl	300 735

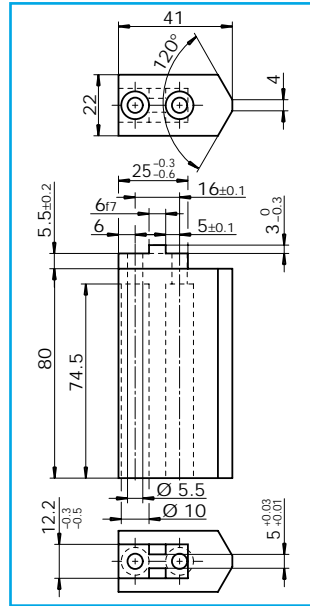

## PGN / PZN 100

Type	Material	Ident-Nr.
ABR 100	Aluminium	300 727
SBR 100	Stahl	300 736

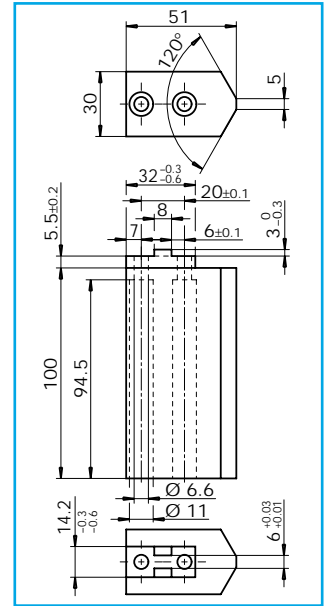

## PGN / PZN 125

Type	Material	Ident-Nr.
ABR 125	Aluminium	300 728
SBR 125	Stahl	300 737

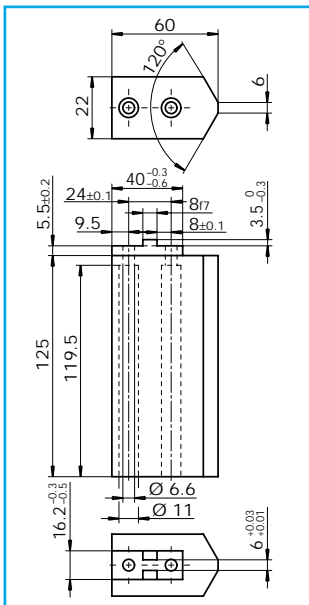

## PGN / PZN 160

Type	Material	Ident-Nr.
ABR 160	Aluminium	300 729
SBR 160	Stahl	300 738

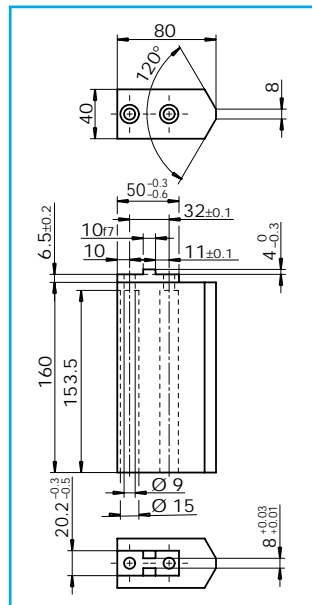

## PGN / PZN 200

Type	Material	Ident-Nr.
ABR 200**	Aluminium	300 751
SBR 200	Stahl	300 739

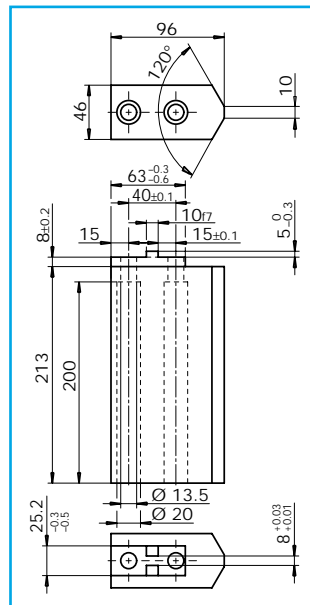

## PGN / PZN 300

Type	Material	Ident-Nr.
ABR 300	Aluminium	300 752
SBR 300	Stahl	300 753

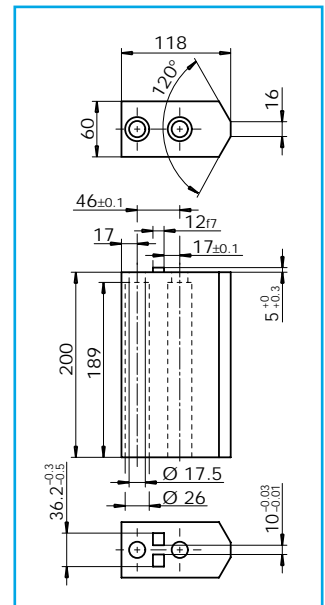

## Zubehör



### Sonderlösungen

Für Ihre besonderen Anforderungen liefern wir Ihnen gerne und schnell kostengünstig Sonderlösungen, Sonderfinger, Anbauplatten und Komplettseinheiten.

Ident-Nr. für je 1 Stück

\*\*nur für PGN 200 geeignet!

# Fingerrohlinge

## Zwischenbacken für PFH Type ZBH

### PFH 30

Type	Material	Ident-Nr.
ZBH 30	Aluminium	300 220

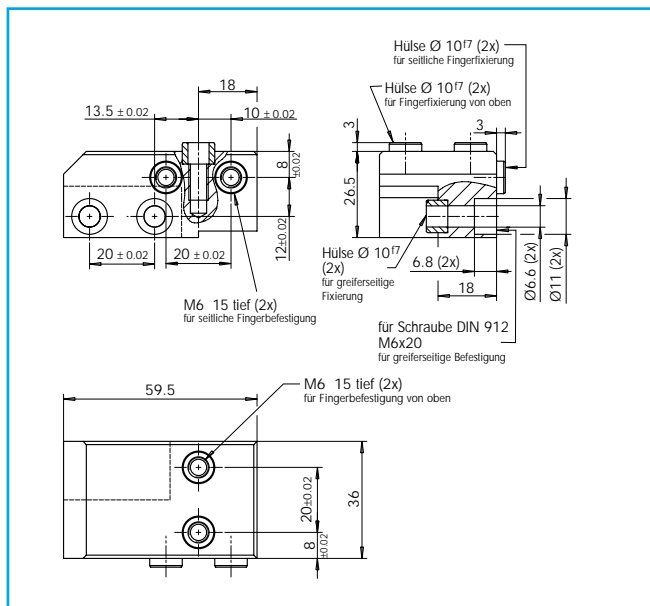

2-Finger-Parallelgreifer  
Type PFH  
mit Sonderfingern

### PFH 40

Type	Material	Ident-Nr.
ZBH 40	Aluminium	300 221

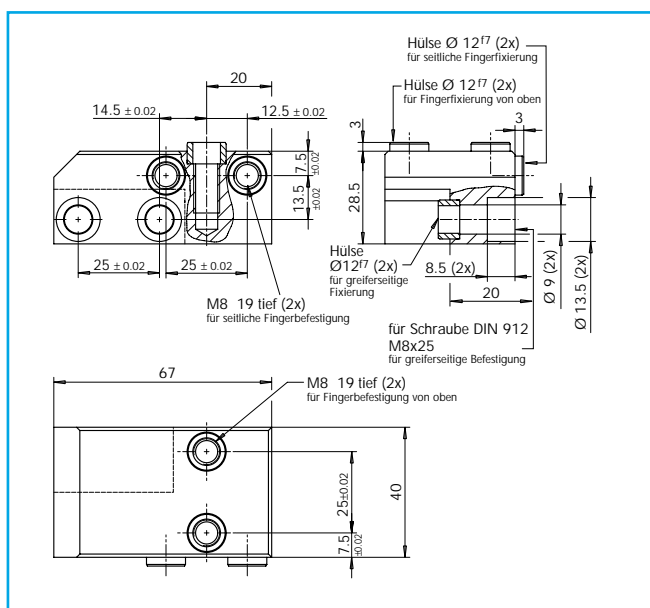

### PFH 50

Type	Material	Ident-Nr.
ZBH 50	Aluminium	300 222

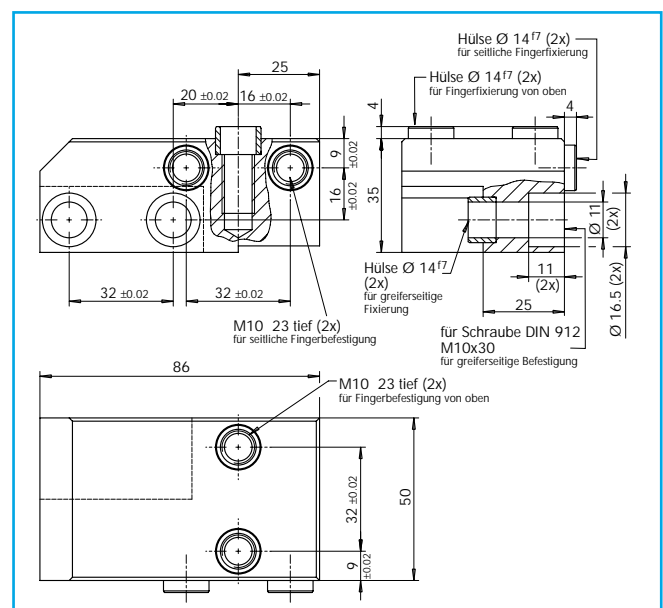

1 Satz = 2 Stück

### Zubehör



#### Sonderlösungen

Für Ihre besonderen Anforderungen liefern wir Ihnen gerne und schnell kostengünstig Sonderlösungen, Sonderfinger, Anbauplatten und Komplettseinheiten.

ABR

ABR+/SBR+

ABR/SBR

ZBH

AAB

RB

ASB

SBR

Quentes

HM/HKI



# Fingerrohlinge

Type	Material	Ident-Nr.
RB 50	Aluminium	300 280

## Fingerrohlinge für Kleinteilegreifer Type RB

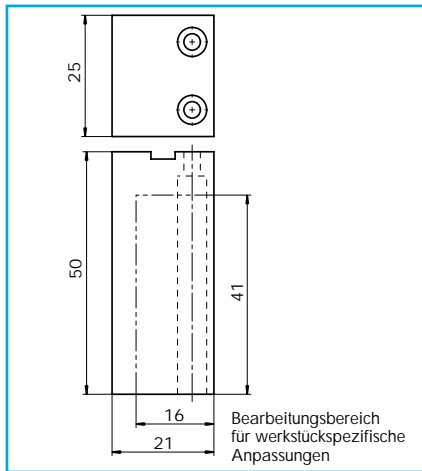

1 Satz = 2 Stück



2-Finger-Parallelgreifer  
Type KTG 50

## ASB

Type	Material	Ident-Nr.
ASB 26	16 MnCr 5	302 703

## Fingerrohlinge für Einlegegreifer UFG Type ASB und SBR (inklusive Schrauben)

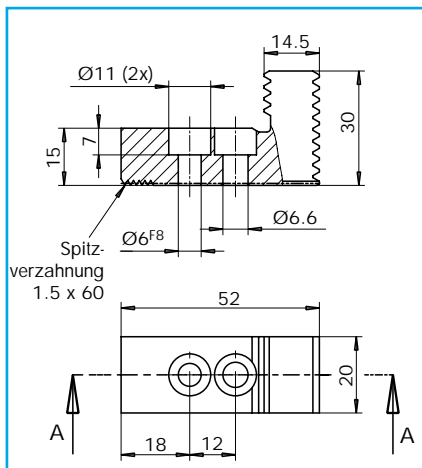

1 Satz = 3 Stück

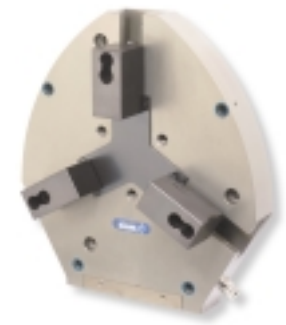

Greifer UFG 26 und UFG 32  
siehe Katalog „Greifsysteme hydraulisch“  
ab Seite 34

## ASB

Type	Material	Ident-Nr.
ASB 32	16 MnCr 5	302 704

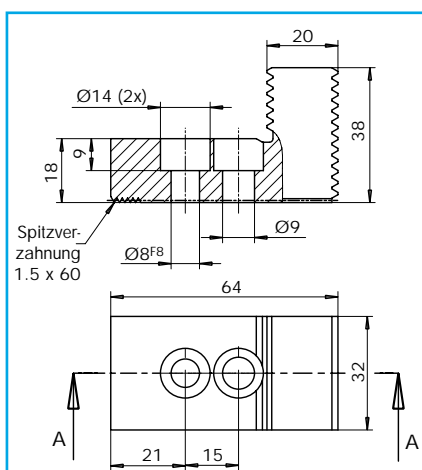

## SBR

Type	Material	Ident-Nr.
SBR 26	16 MnCr 5	302 707

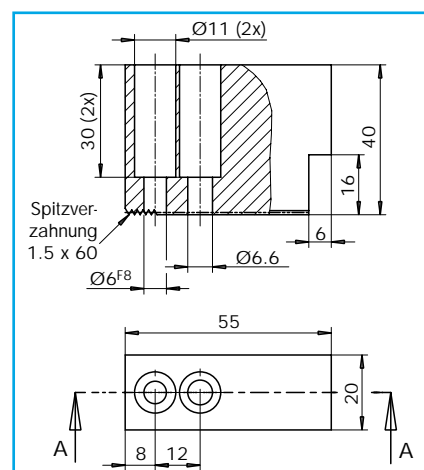

## SBR

Type	Material	Ident-Nr.
SBR 32	16 MnCr 5	302 708

