

# Fingerrohlinge

Fingerrohlinge für  
PGN-plus- und PZN-plus-Baureihe  
Type ABR-plus und SBR-plus  
(inklusive Schrauben)  
Ident-Nr. für je 1 Stück

2-Finger-Parallelgreifer  
Type PGN-plus mit Sonderfingern  
3-Finger-Zentrischgreifer  
Type PZN-plus mit Sonderfingern



## PGN-plus 50

Type	Material	Ident-Nr.
ABR-plus 50	Aluminium	300 009
SBR-plus 50	Stahl	300 019

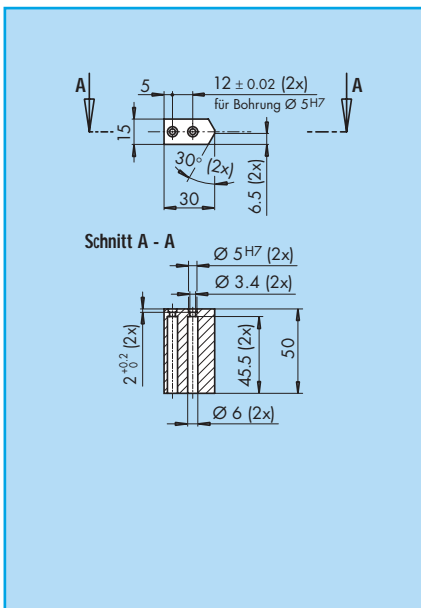

## PGN-plus 64 / PZN-plus 64

Type	Material	Ident-Nr.
ABR-plus 64	Aluminium	300 010
SBR-plus 64	Stahl	300 020

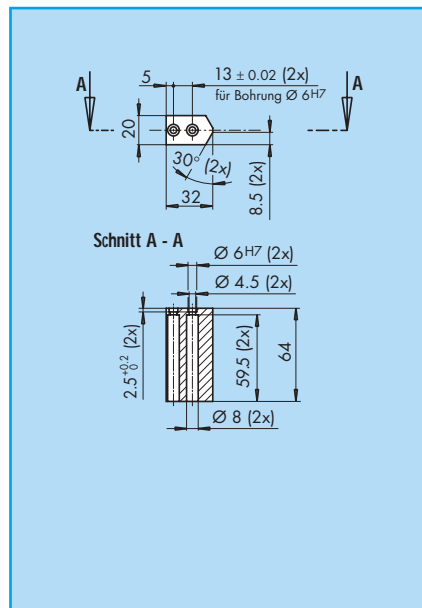

## PGN-plus 80 / PZN-plus 80

Type	Material	Ident-Nr.
ABR-plus 80	Aluminium	300 011
SBR-plus 80	Stahl	300 021

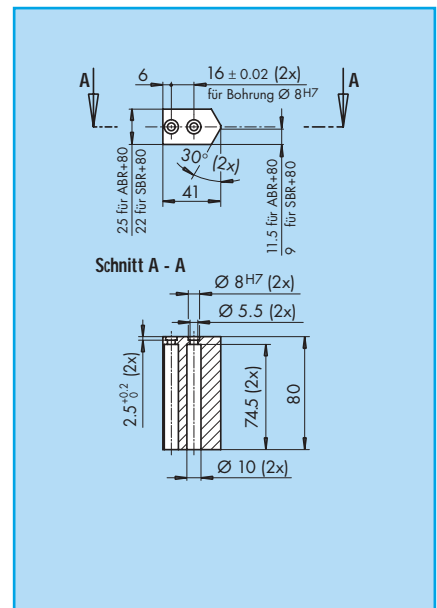

## PGN-plus 100 / PZN-plus 100

Type	Material	Ident-Nr.
ABR-plus 100	Aluminium	300 012
SBR-plus 100	Stahl	300 022

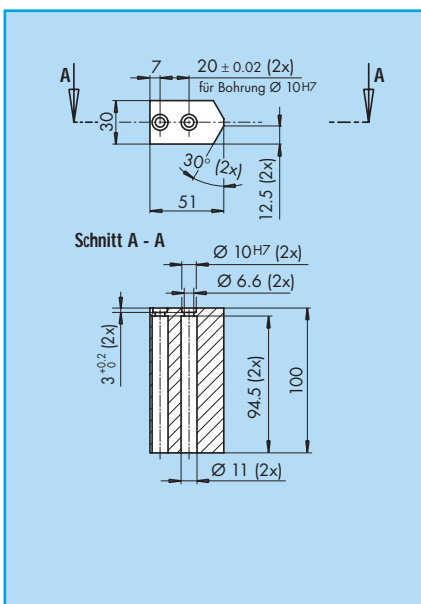

## PGN-plus 125 / PZN-plus 125

Type	Material	Ident-Nr.
ABR-plus 125	Aluminium	300 013
SBR-plus 125	Stahl	300 023

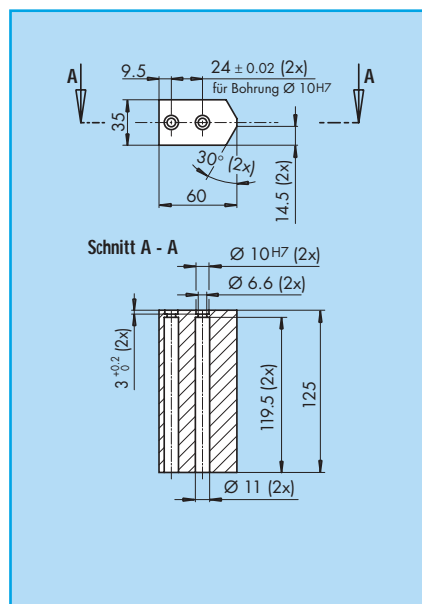

## PGN-plus 160 / PZN-plus 160

Type	Material	Ident-Nr.
ABR-plus 160	Aluminium	300 014
SBR-plus 160	Stahl	300 024

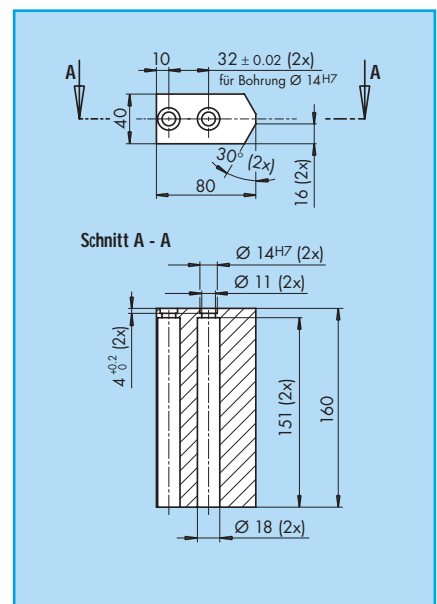

# Fingerrohlinge

Fingerrohlinge für  
PGN-plus- und PZN-plus-Baureihe  
Type ABR-plus und SBR-plus  
(inklusive Schrauben)  
Ident-Nr. für je 1 Stück

2-Finger-Parallelgreifer  
Type PGN-plus mit Sonderfingern  
3-Finger-Zentrischgreifer  
Type PZN-plus mit Sonderfingern



## PGN-plus 200 / PZN-plus 200

Type	Material	Ident-Nr.
ABR-plus 200	Aluminium	300 015
SBR-plus 200	Stahl	300 025

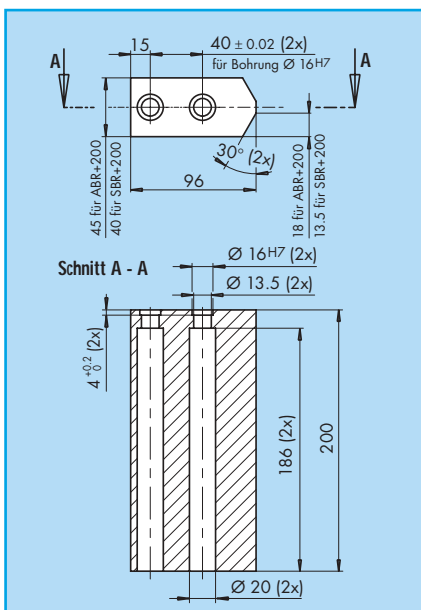

## PGN-plus 300

Type	Material	Ident-Nr.
ABR-plus 300	Aluminium	300 016
SBR-plus 300	Stahl	300 026

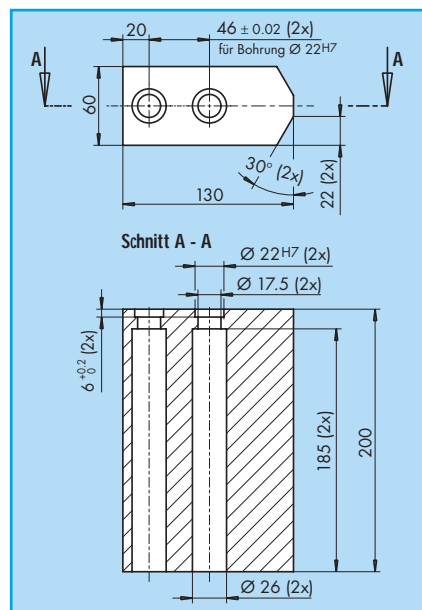

## Zubehör



### Sonderlösungen

Für Ihre besonderen Anforderungen liefern wir Ihnen gerne und schnell kostengünstig Sonderlösungen, Sonderfinger, Anbauplatten und Komplettseinheiten.