



Kit Motors for Rotary Direct Drives

ROL

ROL series frameless torque motors are permanently excited synchronous motors with a high pole count. The rotor carries a number of Nd-Fe-B permanent magnets. The stator lamination is made of cold rolled electric sheets. A star-connected 3 phase AC winding is embedded in the stator slots. The stator core with its windings is pressure fitted into the aluminum alloy housing and encapsulated in sealing compound. The torque motors could run convection cooled or optionally water cooled. The motors will be driven by a current vector controlled AC servo drive. They need to have a suitable rotor position encoder for operation with the servo drive.

Features:

- High torque
- Wide hollow shaft diameter
- Silent run
- Exact positioning
- Maintenance-free operation
- Saves expensive mechanical gear

The motors can be operated with convection or water cooling.

The design allows water cooling by mounting an exterior ring to utilize the machined water channels in the stator housing.

The motors are driven by AC servo drives

Additional accessories

- Bearing
- Feed-back system (e. g. sine encoder)
- Optional water cooling ring around the stator

The optimum winding will be customized to meet the individual customer application. Therefore no winding data is given in this document.

The specified power, torque and mechanical data give a frame for the final design. Mounting threads of stator and rotor can be customized.

BAUTZ

Technical Data

MOTOR TYPE	Cont. Torque M_{n80a}^{*1} (Nm)	Cont. Torque M_{n130a}^{*2} (Nm)	Cont. Torque M_{n130w}^{*3} (Nm)	Peak Torque M_{max} (Nm)	Motor Mass (kg)	Rotor Inertia (kgm ²)	Max. permissible Speed (min ⁻¹)
ROL 180221	17,7	23,7	45,3	69,9	11,5	0,0042	600
ROL 180222	26,1	34,8	70,0	105,2	15,8	0,0063	600
ROL 180223	33,8	45,0	92,8	140,9	20,0	0,0084	600
ROL 180224	41,4	55,1	116,3	176,3	24,3	0,0105	600
ROL 180225	49,3	65,4	140,0	211,9	28,5	0,0126	600
ROL 300441	71	95	190	277	22	0,0435	300
ROL 300442	103	138	285	417	31	0,0654	300
ROL 300443	135	181	383	565	39	0,0871	300
ROL 300444	168	223	478	717	48	0,1090	300
ROL 300445	199	265	578	864	56	0,1310	300
ROL 420661	181	242	465	647	36	0,204	200
ROL 420662	264	352	722	965	50	0,305	200
ROL 420663	343	460	975	1292	64	0,407	200
ROL 420664	426	569	1223	1621	77	0,509	200
ROL 420665	506	675	1485	1951	91	0,611	200
ROL 530881	317	425	833	1135	67	0,45	150
ROL 530882	468	625	1262	1718	92	0,68	150
ROL 530883	611	816	1681	2301	118	0,91	150
ROL 530884	749	999	2117	2886	143	1,13	150
ROL 530885	879	1173	2545	3460	168	1,36	150
ROL 6601101	497	665	1297	1769	76	1,03	120
ROL 6601102	724	968	1984	2651	102	1,54	120
ROL 6601103	949	1264	2653	3538	128	2,05	120
ROL 6601104	1160	1546	3324	4437	151	2,57	120
ROL 6601105	1360	1815	3994	5356	180	3,08	120
ROL 7701321	693	928	1856	2543	77	1,61	100
ROL 7701322	1016	1364	2797	3861	104	2,41	100
ROL 7701323	1333	1782	3742	5149	130	3,21	100
ROL 7701324	1637	2183	4693	6439	156	4,01	100
ROL 7701325	1930	2567	5647	7752	182	4,82	100
ROL 8801541	925	1238	2476	3405	108	3,58	86
ROL 8801542	1356	1820	3767	5132	144	5,38	86
ROL 8801543	1778	2377	5039	6869	181	7,17	86
ROL 8801544	2182	2909	6313	8641	217	8,96	66
ROL 8801545	2573	3421	7595	10367	253	10,75	86
ROL 10001761	1206	1615	3230	4506	125	4,92	75
ROL 10001762	1769	2374	4867	6790	167	7,39	75
ROL 10001763	2319	3101	6512	9054	209	9,88	75
ROL 10001764	2877	3836	8247	11353	250	12,31	75
ROL 10001765	3425	4554	10019	13754	292	14,77	75

*1 Rated torque at 80°C, convection cooling

*2 Rated torque at 130°C, convection cooling

*3 Rated torque at 130°C, water cooling

Order Code

ROL nnn(n) nn(n) n - x -

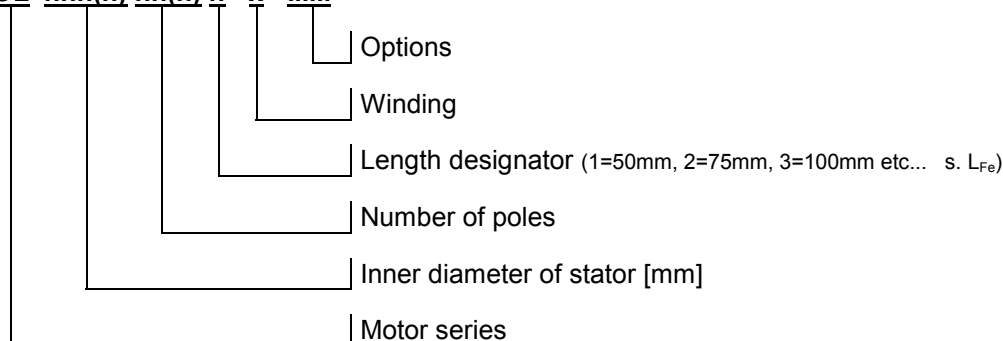

Dimensions

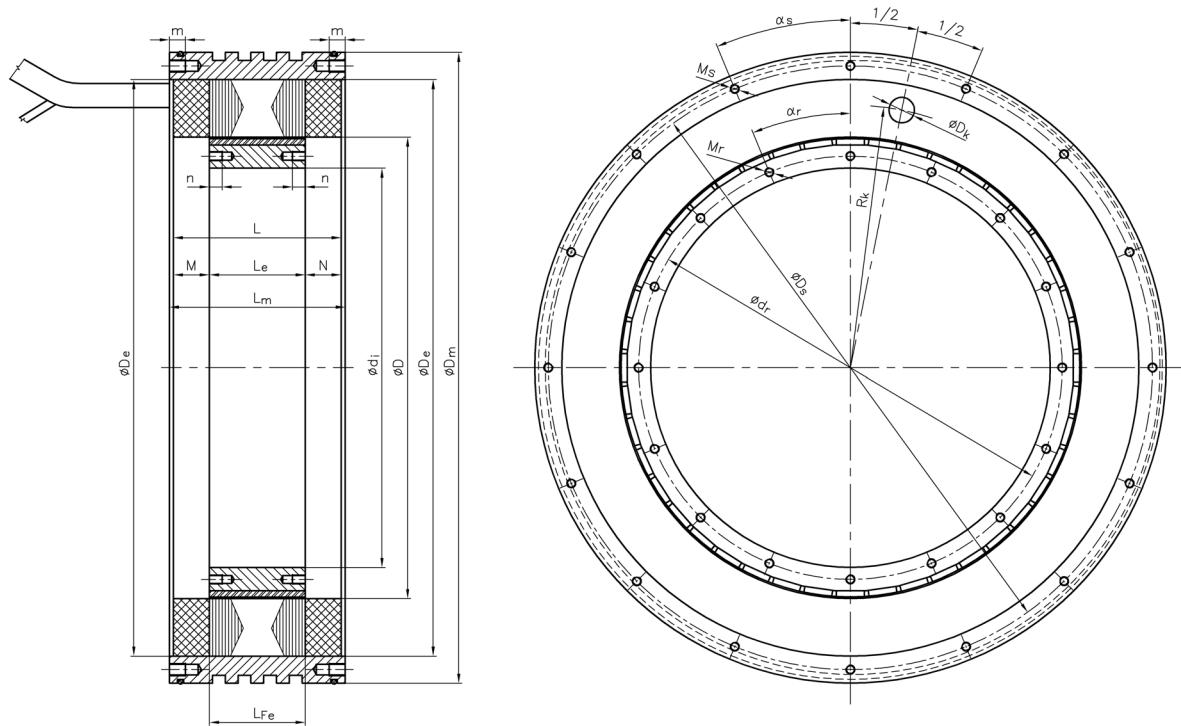

Type ROL		18022	30044	42066	53088	660110	770132	880154	1000176
D_e	mm	180h7	300h7	420h7	530h7	660h7	770h7	880h7	1000h7
D	mm	115H7	230H7	345H7	460H7	575H7	690H7	805H7	920H7
d_i	mm	80H8	195H8	300H8	420H8	530H8	650H8	750H8	870H8
L_{Fe}	mm	50,75,100 125,150	50,75,100 125,150	50,75,100 125,150	50,75,100 125,150	50,75,100 125,150	50,75,100 125,150	50,75,100 125,150	50,75,100 125,150
No. of Poles		22	44	66	88	110	132	154	176
D_m	mm	200h7	320h7	450h7	565h7	700h7	810h7	920h7	1040h7
L_m	mm	L _{Fe} + 50	L _{Fe} + 50	L _{Fe} + 50	L _{Fe} + 50	L _{Fe} + 60	L _{Fe} + 60	L _{Fe} + 60	L _{Fe} + 60
M	mm	20	20	20	20	25	25	25	25
N	mm	20	20	20	20	25	25	25	25
L_e	mm	L _{Fe} + 2	L _{Fe} + 2	L _{Fe} + 2	L _{Fe} + 2	L _{Fe} + 2	L _{Fe} + 2	L _{Fe} + 2	L _{Fe} + 2
D_s	mm	190 - 0,2	310 - 0,2	434 ± 0,1	545 ± 0,1	680 ± 0,1	785 ± 0,1	900 ± 0,1	1020 ± 0,1
M_s	mm	12 x M6	16 x M6	12 x M8	16 x M8	20 x M8	24 x M8	20 x M10	24 x M10
α_s	°	30° ± 5'	22°30' ± 2'	30° ± 2'	22°30' ± 1'	18° ± 1'	15° ± 1'	18° ± 1'	15° ± 1'
m	mm	15	15	20	20	20	20	25	25
d_r	mm	91 + 0,2	206 + 0,2	316 ± 0,1	434 ± 0,1	546 ± 0,1	664 ± 0,1	771 ± 0,1	889 ± 0,1
M_r	mm	12xM6	16xM6	12xM8	16xM8	20xM8	24xM8	20xM10	24xM10
α_r	°	30° ± 10'	22°30' ± 5'	30° ± 2'	22°30' ± 1'	18° ± 1'	15° ± 1'	18° ± 1'	15° ± 1'
n	mm	15	15	20	20	20	20	25	25
D_k	mm	12	12	12	12	14	14	14	14
R_k	mm	82	142	202	257	321	376	431	491

Sales and Service

We are committed to quality customer service. In order to serve you in the most effective way please contact your local sales representative for assistance.

If you do not know the local sales representative please contact our customer support.

EUROPE

Visit the European Danaher Motion Website at **www.Danaher-Motion.de** for set-up software upgrades, application notes, technical publications and the most recent version of our product manuals.

Danaher Motion Customer Support – Europe

Internet	www.Danaher-Motion.de
E-Mail	info@Danaher-Motion.de
Phone	+49(0)203-9979-0
Fax	+49(0)203-9979-155

NORTH AMERICA

Visit the North American Danaher Motion Website at **www.DanaherMotion.com** for set-up software upgrades, application notes, technical publications and the most recent version of our product manuals.

Danaher Motion Customer Support – Radford

Internet	www.MotionVillage.com
E-Mail	servo@kollmorgen.com
Phone	001-800-777-3786
Fax	001-540-639-1574